



THE CORPORATION OF THE TOWNSHIP OF SOUTHWOLD

- A G E N D A -

Monday April 29, 2024

REGULAR MEETING OF COUNCIL

7:00 p.m., Council Chambers, Fingal/Via Video Link

1. CALL TO ORDER

2. ADDENDUM TO AGENDA

3. DISCLOSURE OF PECUNIARY INTEREST

4. ADOPTION AND REVIEW OF MINUTES

- (a) Draft Minutes of the Regular Council Meeting of April 8, 2024
- (b) Draft Minutes of the Young at Heart Committee Meeting of April 10, 2024

5. DELEGATION

6. DRAINAGE

- (a) Section 78 (1.1) Request for Major Improvement and Appointment of Engineer – Bowlby-Futcher Drain
- (b) Appointment of Engineer – Best Drain
- (c) DRA 2024-02 Tender Results – Palmer Drain 2023

7. PLANNING

8. REPORTS

- (a) PW 2024-04 Supply of Two Tandem Axle Plow Trucks
- (b) ENG 2024-30 Public Works Design Build Award
- (c) ENG 2024-31 Award of Organics Processing
- (d) FIN 2024-11 2024 Annual Repayment Limit
- (e) CAO 2024-24 Talbotville Street Naming – Plans of Condominium
- (f) CAO 2024-25 Township Organics Policy
- (g) County Council Highlights – April 9, 2024

9. CORRESPONDENCE

- (a) Proposal for Bar at Baseball Tournaments
- (b) Assessment of Bill 185, Cutting Red Tape to Build More Homes Act, 2024 and the Proposed Provincial Planning Statement, 2024

10. BY-LAWS

- (a) By-law No. 2024-23, being a by-law to provide for drainage works, Larson Drain East 2024, third and final reading
- (b) By-law No. 2024-25, being a by-law to enter into an agreement for organic waste processing.
- (c) By-law No. 2024-26, being a By-law to confirm the resolutions and motions of the Council of the Township of Southwold, which were adopted on April 29, 2024

11. OTHER BUSINESS *(For Information Only)*

12. CLOSED SESSION

- (a) A proposed or pending acquisition or disposition of land by the municipality or local board (Section 239 (2)(c)) – Shedden Housing Development Lands
- (b) A position, plan, procedure, criteria or instruction to be applied to any negotiations carried on or to be carried on by or on behalf of the municipality or local board (Section 239 (2)(k)) – Talbotville Industrial Lands

13. ADJOURNMENT: NEXT REGULAR MEETING OF COUNCIL
Monday May 13, 2024 @ 7:00 P.M.
Council Chambers, Fingal/Via Video Link



THE CORPORATION OF THE TOWNSHIP OF SOUTHWOLD

MINUTES

Regular Council Meeting
Monday April 8, 2024
7:00 p.m. Council Chambers, Fingal/Via Video Link

COUNCIL PRESENT: Mayor Grant Jones
Deputy Mayor Justin Pennings
Councillor John Adzija
Councillor Sarah Emons
Councillor Scott Fellows

ALSO PRESENT: Lisa Higgs, CAO/Clerk
Michele Lant, Director of Corporate Services/Treasurer
Aaron VanOorspronk, Director of Infrastructure & Development Services
Jeff McArthur, Director of Emergency Services/Fire Chief
Paul Van Vaerenbergh, Public Works Superintendent
Brent Clutterbuck, Drainage Superintendent
Danielle Truax, Planner
June McLarty, Deputy Clerk

Mayor Grant Jones called the meeting to order at 7:00 p.m.

ADDENDUM TO AGENDA:

12. CLOSED SESSION

- (d) Personal Matters about an identifiable individual, including municipal or local board employees (Section 239 (2)(b)) – Personal Statement from Councillor

DISCLOSURES: Councillor Fellows declared a conflict on item 8d.

ADOPTION AND REVIEW OF MINUTES:

Council Minutes – Adopt

2024-107 Deputy Mayor Pennings – Councillor Fellows

THAT the Minutes of the Regular Council Meeting of March 25, 2024 are hereby adopted.

CARRIED

Committee Minutes – Review

2024-108 Councillor Adzija – Councillor Fellows

THAT Council has reviewed the draft minutes of the Canada Day Committee Meeting of March 20, 2024 and the draft minutes of the Shedden Recreation and Keystone Complex Committee Meeting of March 21, 2024.

CARRIED

DRAINAGE:

Larson Drain East 2024

Mtg to Consider Report – Larson Drain East 2024

2024-109 Deputy Mayor Pennings – Councillor Fellows

THAT the Meeting to Consider the Report for the Larson Drain East 2024 forms at **7:02 p.m.**

CARRIED

Chairperson Jones called the meeting to order. He stated that this is the Meeting to Consider the Report for the Larson Drain East 2024 dated March 27, 2024 prepared by the Engineer George Vereyken of Spriet Associates. This report was submitted to the Clerk of the Township of Southwold on March 27, 2024. The purpose of this meeting is to allow the landowners and other affected parties to be given the opportunity to voice their concerns relating to any aspect of this report.

Matters dealing specifically with assessments including where any land or road has been assessed too high or too low, any land or road that should have been assessed but has not been, or the land use was not duly considered will be dealt with by the Court of Revision at a date to be determined after the passing of a Provisional By-Law.

Chairperson Jones asked if everyone was notified of this Meeting to Consider the Report in an appropriate way that was required to be notified under the Drainage Act. The Clerk responded yes on April 1, 2024, the required notice of this meeting was sent by regular mail,

or by email to all landowners and affected parties required to be notified under Section 41 of the Drainage Act. Included with the notice was a copy of the Report of the Engineer for the Larson Drain East 2024, Dated March 27, 2024

Engineer George Vereyken presented the report to Council. It was also noted that a revised plan for Block 179 was circulated to staff and the requestor. There were no objections. Mr. Vereyken also reported that cost matter for this drain will also be addressed tonight. No concerns were reported for the cost matters.

No questions were asked from the members of Council or the public.

Larson Drain East 2024

2024-110 Councillor Emons – Deputy Mayor Pennings

THAT Council consider provisional By-law No. 2024-23 for the Larson Drain East 2024; and

THAT Council authorizes staff to initiate the tender process, if required, for the improvement of the Larson Drain East 2024; and

THAT Court of Revision for the Larson Drain East 2024 will be held virtually/in-person at 7:00 p.m. on May 13, 2024.

CARRIED

Chairperson Jones stated that later during the meeting, Council will be passing provisional by-law No. 2024-23. The Clerk will be mailing a copy of the Provisional By-law duly passed tonight to the Landowner and affected parties as required by Section 46 of the Drainage Act along with the notice of the Court of Revision for the Larson Drain East 2024 on May 13, 2024 at 7:00 p.m.

Adjournment of Mtg to Consider Report – Larson Drain East 2024

2024-111 Councillor Adzija – Deputy Mayor Pennings

THAT the Meeting to Consider the Report for the Larson Drain East 2024 hereby adjourns and the regular meeting of Council reconvenes at **7:07 p.m.**

CARRIED

Appointment of Engineer – Section 78(1.1) – Jones Drain

2024-112 Councillor Fellows – Deputy Mayor Pennings

THAT Council of the Township of Southwold receives the Section 78(1.1) petition under the Drainage Act for an improvement to municipal drain, as described in the petition submitted by the Township of Southwold, and decides to proceed with the drainage works; and

THAT Council instructs the Clerk to send the notice required under Section 5(1)(b) of the Drainage Act to the prescribed persons identified in Ontario Regulation 500/21 section 1); and

THAT Council Instructs the Clerk to Send Notice under Section 6(1) of the Drainage Act to the prescribed persons in Ontario Regulation 500/21 Section 2.) (Kettle Creek Conservation Authority); and

THAT Council Instructs the Clerk to Send Notice to OMAFRA under Section 7(1) of the Drainage Act; and

THAT Council will now appoint engineer Spriet Associates under Section 8.1 of the Drainage Act.

CARRIED

Appointment of Engineer - Section 78(1.1) – Edison Drain

2024-113 Councillor Adzija – Councillor Fellows

THAT Council will appoint engineer Spriet Associates under Section 8.1 of the Drainage Act to prepare the report for the Edison Drain.

CARRIED

Section 78 (1.1) Petition – Best Drain

2024-114 Councillor Emons – Councillor Fellows

THAT Council of the Township of Southwold receives and decides to proceed with the petition under Section 78 (1.1) of the Drainage Act that was received from A. and M. Kemmerling; and,

THAT Council instruct the Clerk to send required notice under Section 5(1)(b) of the Drainage Act to the Lower Thames Valley Conservation Authority, OMAFRA and the requesters notifying them that they intend to appoint an Engineer to prepare the necessary reports under the appropriate section of the Drainage Act upon the passing of the 30 days notification specified in sections 6(1) and 7(1) of the Drainage Act.

CARRIED

PLANNING:

MV 2024-01 and MV 2024-02

In attendance: S. Congdon, Strik Baldinelli Moniz and N. McDowell, Due North Design and Drafting Inc.,

MV 2024-01, Farhi Holdings Corp. C/O Strik Baldinelli Moniz , 7 Optimist Drive and MV 2024-02 Willmore, C/O Nicole McDowell, Due North Design & Drafting Inc., 8934 Iona Road

2024-115 Deputy Mayor Pennings – Councillor Emons

THAT the regular Council meeting adjourn to sit as a Committee of Adjustment to hear minor variance applications MV 2024-01, filed by Farhi Holdings Corp. C/O Strik Baldinelli Moniz, 7 Optimist Drive and MV 2024-02 Willmore, C/O Nicole McDowell, Due North Design & Drafting Inc., 8934 Iona Road at **7:15 p.m.**

CARRIED

MV 2024-01 and MV 2024-02, Adjournment of Committee of Adjustment

2024-116 Councillor Adzija – Councillor Emons

THAT the meeting of the Committee of Adjustment to hear applications MV 2024-01, filed by Farhi Holdings Corp. C/O Strik Baldinelli Moniz , 7 Optimist Drive and MV 2024-02 Willmore, C/O Nicole McDowell, Due North Design & Drafting Inc., 8934 Iona Road adjourns and the regular meeting of council reconvenes at **7:34 p.m.**

CARRIED

PLA 2024-05 Application for Consent E23-24 Kikkert C/O H. Button, 8169 Union Road

2024-117 Deputy Mayor Pennings – Councillor Emons

THAT Council for the Township of Council recommends approval of Consent Application E23-24 to Elgin County Land Division Committee for the creation of a new residential lot from the property located at 8169 Union Road subject to the Lower Tier Municipal conditions provided in Appendix 2 of Report PLA 2024-05.

CARRIED

**PLA 2024-06 Application for Consent E29-24 Aulakh Enterprises Ltd C/O
J. Horn, 10401 Sunset Road**

2024-118 Councillor Adzija – Councillor Fellows

THAT Council recommend approval to the Elgin County Land Division Committee for Consent Application E29-24 for the addition of a parcel of land measuring approximately 4.8m by 79.9m from 10401 Sunset Road to the abutting property at 10377 Sunset Road subject to the recommended conditions provided in Appendix Two of Report PLA 2024-06.

CARRIED

REPORTS:

FIR 2024-05 Activity Report – March 2024

Jeff McArthur presented his report to Council. Chief McArthur also acknowledged the Fire Department for the assisting with the eclipse. There were no major issues reported from this event.

CBO 2024-07 Activity Report – March 2024

This report was presented to Council.

PW 2024-02 Supply of Two Roadside Mowers

2024-119 Councillor Adzija – Deputy Mayor Pennings

THAT Council accepts the bid in the amount of \$37,000.00, excluding HST for the Bush Hog 5110 Flex Wing Rotary Mower and the bid of \$61,900.00 excluding HST for the Kronos Extendo 610 Boom Mower, both from Delta Power Equipment Sparta.

Councillor Fellows vacated his seat.

PW 2024-03 Supply of Sidewalk Plow

2024-120 Councillor Adzija – Councillor Emons

THAT Council accepts the bid in the amount of \$207,627.00, excluding HST. for a new Trackless Sidewalk Plow.

CARRIED

Councillor Fellows returned to his seat.

ENG 2024-25 Activity Report – February 2024

Aaron VanOorspronk presented his report to Council.

ENG 2024-26 Thomas Road Engineering Award

2024-121 Councillor Emons – Deputy Mayor Pennings

THAT Report ENG 2024-26 relating to the Thomas Road Engineering Award, be received for information; and

THAT the proposal submitted by WT Infrastructure Solutions Incorporated in the amount \$109,570.00 plus HST be accepted.

CARRIED

ENG 2024-27 Organics Processing Contract

2024-122 Councillor Emons – Councillor Adzija

THAT Report ENG 2024-27 relating to the Organics Processing Contract, be received for information; and

THAT Council Direct Staff to prepare and execute a 20-year contract with Convertus Group; and

THAT Council Direct Staff to prepare a User Fee By-Law Amendment using a straight-line adjustment for user fees per property for organic collection in the urban areas of Talbotville, Ferndale, and Lynhurst.

CARRIED

ENG 2024-28 Public Works Septic System

2024-123 Councillor Adzija – Councillor Fellows

THAT Report ENG 2024-28 relating to the Public Works Septic System, be received for information; and

THAT Council approve a budget of \$ 40,000 to replace the Public Works Septic System.

CARRIED

ENG 2024-29 Authorize Invite Only Tender

2024-124 Deputy Mayor Pennings – Councillor Emons

THAT Report ENG 2024-29 relating to Authorizing an Invite Only Tender for the Talbotville Fire Hall Site Works be received for information; and

THAT Council approve an invitation only bid for the site works of the Talbotville Firehall.

CARRIED

FIN 2024-10 Development Charges Summary Report

2024-125 Deputy Mayor Pennings – Councillor Fellows

THAT Council receive Report No. FIN 2024-10 prepared in accordance with Section 12 of O.Reg.82/98 of the Development Charges Act, 1997.

CARRIED

CAO 2024-18 Activity Report – March 2024

Lisa Higgs presented her report to Council.

CAO 2024-19 Digital Sign Policy

2024-126 Councillor Fellows – Deputy Mayor Pennings

THAT the Council of the Township of Southwold receives the report of the CAO/Clerk titled Digital Sign Policy and Procedure as information; and,

THAT Council adopts the Digital Sign Policy and Procedure attached as Schedule 'A'.

CARRIED

Break – 8:37 p.m. – 8:42 p.m.

CORRESPONDENCE:

- Elgin Group Police Services Board Meeting Minutes – November 15, 2023 and February 26, 2024
- City of Brantford Resolution for Home Heating Sustainability
- Lower Thames Valley Conservation Authority 2024 Approved Budget

Support for City of Brantford Resolution for Home Heating Sustainability

2024-127 Councillor Adzija – Deputy Mayor Pennings

BE IT RESOLVED THAT the Council of the Township of Southwold supports the attached resolution that was passed by the City of Brantford regarding Home Heating Sustainability; and,

THAT a copy of this resolution be sent to Elgin-Middlesex-London Member of Parliament, the Honourable Karen Vecchio, Elgin Middlesex-London Member of Provincial Parliament, the Honourable Rob Flack, The Federal Minister of the Environment and Climate Change, The Honourable Steven Guilbeault, The Provincial Minister of Environment, Conservation and Parks, The Honourable Andrea Khanjin and the City of Brantford.

Council reviewed the other items under Correspondence.

BY-LAWS:

- By-law No. 2024-23, being a by-law to provide for drainage works – Larson Drain East 2024

By-law 2024-23

2024-128 Councillor Adzija – Councillor Emons

THAT By-law No. 2024-23, be read a first and second time this 8th day of April, 2024.

CARRIED

OTHER BUSINESS:

- Southwestern Public Health RE: Actions to Reduce Alcohol-Related Harms Report
- Ministry of Finance RE: Property Tax Update

Council reviewed the items under Other Business

CLOSED SESSION:

2024-129 Councillor Adzija – Deputy Mayor Pennings

THAT Council of the Township of Southwold now moves again into a session of the meeting that shall be closed to the public at **8:48 p.m.** in accordance with Section 239 (2) of the Municipal Act, S.O. 2001, c. 25 for discussion of the following matters;

- Personal Matters about an identifiable individual, including municipal or local board employees (Section 239 (2)(b)) – 2 items – Infrastructure and Development Services Staffing
- A proposed or pending acquisition or disposition of land by the municipality or local board (Section 239 (2)(c)) – 2 items – CN Rail Lands and Pumping Station Fingal
- A position, plan, procedure, criteria or instruction to be applied to any negotiations carried on or to be carried on by or on behalf of the municipality or local board (Section 239 (2)(k)) – Industrial Lands
- Personal Matters about an identifiable individual, including municipal or local board employees (Section 239 (2)(b)) – Personal Statement from Councillor

Adjournment of Closed Session

2024-130 Councillor Adzija – Councillor Fellows

THAT Council of the Township of Southwold adjourns the Closed Session of the Regular Council meeting at **10:05 p.m.**

CARRIED

STAFF DIRECTION

Staff were directed by Council to the 6 items that were discussed in the Closed Session.

Confirming By-law

- By-law No. 2024-24, being a By-law to confirm the resolutions and motions of the Council of the Township of Southwold, which were adopted on April 8th, 2024

Confirming By-law

2024-131 Councillor Emons – Councillor Fellows

THAT By-law No. 2024-24 be read a first and second time, considered read a third time and finally passed this 8th day of April, 2024.

CARRIED

ADJOURNMENT:

2024-132 Councillor Fellows – Deputy Mayor Pennings

THAT Council for the Township of Southwold adjourns this Regular meeting of Council at **10:05 p.m.**

CARRIED

Mayor
Grant Jones

CAO/Clerk
Lisa Higgs

4. Spring Fling Lunch

The Spring Fling lunch was a success. A lot of great feedback was received. The meal was amazing. Dividing the duties up between the distribution of the plants and meals made everything flow well.

5. Summer Picnic

The cost of the summer picnic will be \$15.00 per person.

6. Future Events

Gramma's Wartime Kitchen event will be held on Thursday May 30th, 2024 from 1:00 p.m. -3:00 p.m. at the complex. This event highlights women's roles on the home front during the wartime. The presentation will include rationing snacks and wartime memories. Sarah will do a poster for this free event. Attendees don't have to live in the Township to attend but will need to call the office or email June to reserve their spot. A cap number of attendees will need to be determined.

The Streeterly will be catering the October drive thru meal on October 10, 2024. Cost is \$20.00 per person. The meal will consist of meat loaf, scalloped potatoes, baked beans, coleslaw and a bun. The dessert will be pumpkin flavoured.

7. Other Business

Pat Stannard has submitted her resignation from the committee effective July 1st, 2024.

8. Adjournment and Next Meeting

Resolution No. 2024-09 Moved by: Deb Logghe
Seconded by: Karen Auckland

RESOLVED that the meeting be adjourned at **2:28 p.m.**
to meet again at **1:30 p.m.** on **May 21st, 2024** via Webex.

DISPOSITION: Carried

Notice of Request for Drain
Major Improvement
Drainage Act, R.S.O.
1990, c. D.17, subs. 78 (1.1)

To: The Council of the Corporation of the Municipality of Southwold

Re: Bowlby Futcher Drain - By-Law 948

MAIN Drain + Branches "E" + "F"
(Name of Drain)

In accordance with section 78 (1.1) of the *Drainage Act*, take notice that I, as owner of land affected, request that the above mentioned drain be improved.

The Major Improvement Project work being requested is (check all appropriate boxes):

- Changing the course of the drainage works;
- Making a new outlet for the whole or any part of the drainage works;
- Constructing a tile drain under the bed of the whole or any part of the drainage works;
- Constructing, reconstructing or extending bridges or culverts;
- Extending the drainage works to an outlet;
- Improving or altering the drainage works if the drainage works is located on more than one property;
- Covering all or part of the drainage works;
- Consolidating two or more drainage works; and/or
- Any other activity to improve the drainage works, other than an activity prescribed by the Minister as a minor improvement.

Provide a more specific description of the proposed drain major improvement you are requesting:

Improve the 1928 drain to modern STANDARDS. INVESTIGATE
EXTENDING the branches of "C" + "D" into the improved main
drain in Lot 31.

Property Owners

- Your municipal property tax bill will provide the property description and parcel roll number.
- In rural areas, the property description should be in the form of (part) lot and concession and civic address.
- In urban areas, the property description should be in the form of street address and lot and plan number, if available.

Property Description

Con NTRE Pt Lots 32,33 Pt as RP 11R2733 Part 1

Ward or Geographic Township
Southwold

Parcel Roll Number
34 24 000 007 07200

If property is owned in partnership, all partners must be listed. If property is owned by a corporation, list the corporation's name and the name and corporate position of the authorized officer. Only the owner of the property may request a drain improvement.

Ownership

Corporation

If you need to provide additional information, please attach along with this form.

Corporation (The individual with authority to bind the corporation must sign the form)

Name of Signing Officer (Last, First Name) (Type/Print)	Position Title
---	----------------

Name of Corporation
Nor-Mac Farms Ltd

I have the authority to bind the Corporation.
Signature _____ Date (yyyy/mm/dd)
2024/04/10

Enter the mailing address and primary contact information of property owner below:

Last Name	First Name	Middle Initial
-----------	------------	----------------

Mailing Address

Unit Number	Street/Road Number	Street/Road Name	PO Box
City/Town	Province	Postal Code	
Telephone Number	Cell Phone Number (Optional)	Email Address (Optional)	

To be completed by recipient municipality:
Notice filed this 10th day of April 20 24

Name of Clerk (Last, First Name) Higgs, Lisa	Signature of Clerk
--	--------------------

To: The Council of the Corporation of the Municipality of Southwold

Re: Best Drain

(Name of Drain)

In accordance with section 78 (1.1) of the *Drainage Act*, take notice that I, as owner of land affected, request that the above mentioned drain be improved.

The Major Improvement Project work being requested is (check all appropriate boxes):

- Changing the course of the drainage works;
- Making a new outlet for the whole or any part of the drainage works;
- Constructing a tile drain under the bed of the whole or any part of the drainage works;
- Constructing, reconstructing or extending bridges or culverts;
- Extending the drainage works to an outlet;
- Improving or altering the drainage works if the drainage works is located on more than one property;
- Covering all or part of the drainage works;
- Consolidating two or more drainage works; and/or
- Any other activity to improve the drainage works, other than an activity prescribed by the Minister as a minor improvement.

Provide a more specific description of the proposed drain major improvement you are requesting:

Looking to improve the capacity flowing through the Best Drain - water is pooling on both sides of Fingal Line anytime a significant rain event happens and it takes days to go away.

Property Owners

- Your municipal property tax bill will provide the property description and parcel roll number.
- In rural areas, the property description should be in the form of (part) lot and concession and civic address.
- In urban areas, the property description should be in the form of street address and lot and plan number, if available.

Property Description

33813-33821 Fingal Line CON STRE Pt Lot 7

Ward or Geographic Township

Southwold Township

Parcel Roll Number



If property is owned in partnership, all partners must be listed. If property is owned by a corporation, list the corporation's name and the name and corporate position of the authorized officer. Only the owner of the property may request a drain improvement.

Ownership

Partnership

If you need to provide additional information, please attach along with this form.

Partnership (Each partner in the ownership of the property must sign the form)

Owner Name (Last, First Name) (Type/Print)	Signature	Date (yyyy/mm/dd)
		2024/04/03
		2024/04/03

Enter the mailing address and primary contact information of property owner below:

Last Name	First Name	Middle Initial

Mailing Address

Unit Number	Street/Road Number	Street/Road Name	PO Box
City/Town Fingal	Province Ontario	Postal Code N0L 1K0	
Telephone Number	Cell Phone Number (Optional)	Email Address (Optional)	

To be completed by recipient municipality:

Notice filed this 3rd day of April 2024

Name of Clerk (Last, First Name) <i>(deputy)</i> McLarty, June	Signature of Clerk <i>-Deputy</i> 
--	---



TOWNSHIP OF SOUTHWOLD

Report to Council

MEETING DATE: April 29, 2024

PREPARED BY: Brent Clutterbuck, Drainage Superintendent

REPORT NO.: DRA 2024-02

SUBJECT MATTER: Palmer Drain 2023 Tender Results

Recommendation:

That Council of the Township of Southwold award the contract for the construction of the Palmer Drain 2023 to VanGorp Drainage and Excavating Inc. for a total cost of \$60,601.50 +HST and instructs the Mayor and Clerk to sign the tender contract.

Purpose:

To award the contract for the construction of the Palmer Drain 2023.

Background:

Tenders were promoted to contractors who have bid on similar projects in the past. An email was sent to twelve (12) drainage contractors who have bid in the past or have expressed interest in Township of Southwold municipal drainage tenders. The email included a copy of the tender documents. The tender closed on Wednesday April 24, 2024 at 1:00pm. The extent of the work comprised that this tender is for the construction of the Palmer Drain 2023, as contained in the reports that forms part of Township of Southwold By-Law 2024-03. There were three (3) tenders submitted on the bids and tender's website by the closing deadline. The Engineer's estimate for the construction portion of this drain is \$65,620.00 plus HST. The Tenders received back varied from approximately 92.4% to 121.6% of the Engineers estimate.

Comments/Analysis: Tender Results

<u>Contractor</u>	<u>Tender Amount</u>	<u>Completion Date</u>
Gillier Drainage Inc.	\$ 70,300.00 +HST	Aug. 1, 2024
VanBree Drainage and Bulldozing Ltd.	\$ 79,770.00 +HST	Dec. 20, 2024
VanGorp Drainage and Excavating Inc..	\$60,601.50 +HST	October 29, 2024

Financial Implications:

The tender submitted by VanGorp Drainage and Excavating Inc. in the amount of \$60,601.50 +HST is approximately 92.4% of the Engineer's estimate.

The tender result has reduced The Township of Southwold's estimated net assessment by about \$1,600.00. The assessment to Bush Line was estimated in the drainage report to be \$22,588.00. From the results of the lower tender, the estimated amount is now \$20,962.00.

As Council may recall, there is a mutual agreement drain to be constructed to the west in the Palmer property. The estimated cost of the extra work to accommodate the extension of the main drain, was \$12,000.00. As a result of the tender, the cost of this work is now about \$13,278.00 or about \$1278.00 more.

The final actual cost of the drain is dependant on the number of tile connections not noted on the plan. Any unforeseen circumstances encountered during construction may result in extra contingencies costs plus actual interest charges.

Strategic Plan Goals:

The above recommendation helps the Township meet the Strategic Plan Goal of:

- Managed Growth
- Welcoming and Supportive Neighbourhoods
- Economic Opportunity
- Fiscal Responsibility and Accountability

**Respectively Submitted by:
Brent Clutterbuck, Drainage
Superintendent
"Submitted electronically"**

**Approved by:
Lisa Higgs, CAO/Clerk
"Approved electronically"**



TOWNSHIP OF SOUTHWOLD

Report to Council

MEETING DATE: April 29, 2024

PREPARED BY: Paul Van Vaerenbergh, Public Works Superintendent

REPORT NO: PW 2024-04

SUBJECT MATTER: Supply of Two New Tandem Axle Plow Trucks

Recommendation(s):

THAT Council accepts the bid in the amount of \$789,750.00 excluding HST for two new tandem axle plow trucks from Viking Cives.

Purpose:

The purpose of this report is to seek the Council's authorization to accept the quote from Viking Cives.

Background:

As part of the Township's approved 2024 Budget, Staff have requested quotation through Canoe Group Procurement for two new tandem plow trucks for delivery and payment in 2025.

Daimler Chrysler currently has a hold on all truck orders due to demand and supply issues. Staff seeks Council authorization to accept the quote and thus lock in the price now to avoid future increases and place us in the que for when orders are taken again. As these trucks will not be received until 2025, we will also avoid future increases expected to rise by 16-20%.

The supplier has informed Staff that, a further savings of \$17,000.00 dollars can be realized by payment of the chassis upon arrival to Viking Cives bringing the total price down to \$772,750.00.

The quote was entered through Canoe to Viking Cives as specialized equipment to match our current fleet in consistent maintenance and operational considerations.

Financial Implications:

The quoted price is within the approved budget of \$910,000.00.

Strategic Plan Goals:

The above recommendation helps the Township meet the Strategic Plan Goal of:

- Managed Growth
- Welcoming and Supportive Neighbourhoods
- Economic Opportunity
- Fiscal Responsibility and Accountability

**Respectfully submitted by:
Paul Van Vaerenbergh, CRSI
Public Works Superintendent
"Submitted Electronically"**

**Approved by:
Lisa Higgs
CAO/Clerk
"Approved electronically"**



TOWNSHIP OF SOUTHWOLD

Report to Council

MEETING DATE: April 29, 2024

PREPARED BY: Paul Van Vaerenbergh, Public Works Superintendent & Aaron VanOorspronk, Director of Infrastructure and Development Services

REPORT NO: ENG 2024-30

SUBJECT MATTER: Public Works Building Design Build Award

Recommendation(s):

THAT Report ENG 2024-30 relating to Public Works Building Design Build Award, be received for information; and

THAT the proposal submitted by Baribeau Construction in the amount \$4,552,830 excluding HST be accepted; and

THAT the project be funded as outlined in Option 2 of this report.

Purpose:

The report is to provide Council with a recommended award to Baribeau Construction for the design-build of a new Public Works Building.

Background:

The Township has been in the process of replacing the existing Public Works Building with an expanded modern facility to continue the delivery of critical services now and into the future. Originally, the Township was delivering the project through a design-bid-build process, with the design phase having a project budget of \$7 million. Further discussions were held to reduce the project costs as part of the 2024 Budget. With the success to date on the Talbotville Firehall using a design-build delivery, Council directed Staff to issue a request for proposal for a new building with a reduced vehicle storage footprint. Drawing on their previous knowledge of the project, Staff engaged RJ Burnside to issue a design-build request for proposal for the revised building layout. Like the previous request, an invite-only request was sent to the same bidders plus one additional one. Out of the seven companies invited to participate, the following chart displays the companies that submitted a proposal with their respective pricing:

	Bidder	Sub Total (excluding allowances & HST)
1	Baribeau Construction	\$3,889,830.00
2	HIRA Construction	\$4,317,900.00
3	Elgin Construction	\$4,514,000.00
4	S.E.M. Construction	\$5,473,040.00

A scoring team, comprised of Township Staff and RJ Burnside, scored the four submissions based on: Qualifications and Expertise of the Team, Experience with Projects of Similar Size, Approach to Design Concept Including Suggested Materials, Schedule, and Costing. The scoring team's consensus was that the proposal from Baribeau Construction is preferred. The main proposal has been attached to this report as Appendix A.

Comment/Analysis:

Staff are pleased with the results of the proposal; all proponents submitted a compliant proposal that delivers a product that will stand the test of time and provide the Township the ability to deliver high-quality services to its residents for the long term. Baribeau has also included some changes that improve the aesthetic appeal of the building, while delivering the project under budget.

The request for proposal included two provisional items for Council's consideration. These items were identified as possible cuts from the project to provide cost savings. Requesting provisional pricing enables Council to assess the impact of adding one or more items to the contract and evaluate the cost benefits.

The first provisional item included for pricing is the addition of 2 bays; this would bring the layout for the vehicle storage back to the original size. For context, staff believe it's important to consider the square foot price of the addition in comparison to the rest of the project. The square footage cost for the building, without the addition, comes to approximately \$263 per square foot; the additional bay price equates to \$69 per square foot. When combined, the additional bays and building bring the square foot cost down roughly to \$212 per square foot. Staff strongly recommend seizing this deeply discounted price to complete the shop for the long term. Any future addition will likely incur a significant cost increase, as it would be treated as a new standalone build. This delivery method, leveraging a private/public sector partnership, resulted in a project delivery with approximately 28-35% savings compared to a similar works building constructed in Zorra Township.

The second provisional item requested for pricing was the construction of a mezzanine in the new building. Staff recommend not carrying it forward. Instead, complete the mezzanine construction as part of the removal of the old works buildings at a future date. The base level construction has been designed to accommodate future construction.

Proponents were also allowed to identify additional options/items and their associated costs that they thought would be beneficial to the project, without automatic inclusion in the base price. Staff do not currently recommend any further additions; however,

Council can review them in the pricing form attached as Appendix B. Staff serve at Council’s pleasure and will include any items as directed.

Staff have prepared a chart below to show the estimated costs of this project, the following allowances, and net HST are shown.

	Expenditures	Budget
Costs To Date (Engineering)	200,000	
Sub Total (Baribeau)	\$3,889,830	
Contingency, Furniture, Utility connection & permit allowances	\$175,000	
Additional 2 Bays	\$363,000	
Contract Administration	\$125,000	
Sub Total with allowances	\$4,752,830	
Total Tender Price including net HST	\$ 4,836,480	\$4,750,000

Although when totalled the project is over budget by \$86,480, the bid still represents good value when previous estimates suggested the project would be \$8.8 million. It’s also important to note that contingency costs may not be used, and that the contract administration is a budget upset limit, only actual costs will be billed to the project, therefore, there is opportunity for actual costs to come in below budgets.

Financial Implications:

Based on received proposals, it is Staff’s opinion that the project received competitive pricing. The table above shows the total tender cost as well as the project budget.

Staff have reviewed funding options for the project, with consideration given to using existing water reserve funds to borrow and be repaid with interest, thereby keeping the funds within the Township’s coffers. After review, Staff would recommend that borrowing against the water reserve fund be used for short term projects with a faster return on investment to try and keep the fund whole for operational cash flow. Given the current status of reserves for the Public Work’s facility, and the large number of growth-related projects in the Township, Staff recommend this project be funded

through a long-term debenture from Infrastructure Ontario. The following charts break down and compares a 30 year and 25 year loan term.

30 Year Term					
Funding Source (B) if borrowed	% Interest	Term	Funding	Annual Payment	Total Interest Paid
Water Reserve	-	-	\$678,000**	-	
Development Charges	-	-	\$150,000	-	
Infrastructure Ontario (B)	5.08%*	30 years	\$ 4,158,479.81	\$ 272,986.99	\$ 4,031,130.01
Total Project Cost			\$ 8,189,609.82		

* interest rate as of April 24, 2024

**water reserve contribution calculated based on usage of building as a percentage

25 Year Term					
Funding Source (B) if borrowed	% Interest	Term	Funding	Annual Payment	Total Interest Paid
Water Reserve	-	-	\$678,000**	-	
Development Charges	-	-	\$150,000	-	
Infrastructure Ontario (B)	5.08%*	25 years	\$ 4,158,479.81	\$ 297,424.57	\$ 3,277,134.56
Total Project Cost			\$ 7,435,614.37		

* interest rate as of April 24, 2024

**water reserve contribution calculated based on usage of building as a percentage

In the 2024 Budget, Council identified a budget of 4.75 million with an annual repayment of \$ 295,774 for the construction of a new public works facility. Understanding that when considering the costs incurred to date, and project budget costs, the project is over budget by \$86,480 dollars, Staff used a thirty-year loan to reduce the annual repayment to \$ 272,987, which maintains a yearly impact that’s under budget. This thirty-year term would also roughly equate to the halfway point on a facilities lifecycle, if the loan repayment is directed to the facility reserve it should leave the future budget with healthy funding to complete that replacement activity with minimal or no debenture.

Strategic Plan Goals:

The above recommendation helps the Township meet the Strategic Plan Goal of:

- Managed Growth
- Welcoming and Supportive Neighbourhoods
- Economic Opportunity
- Fiscal Responsibility and Accountability

Respectfully Submitted by:
Aaron VanOorspronk, CET.
Director of Infrastructure and
Development Services
"Submitted electronically"

Approved by:
Lisa Higgs, CAO/Clerk
"Approved electronically"



BARIBEAU
CONSTRUCTION
EST. 1987

STEELWAY
BUILDING SYSTEMS

Baribeau Construction (London) Limited proposal for

TOWNSHIP OF SOUTHWOLD

Design-Build Proposal for Public Works Operations Centre
RFP# 2024 PW-002

Project Address: 35663 Fingal Line, Fingal, ON

April 16, 2024

INFO@BARIBEAUCONSTRUCTION.COM | (519) 268-8343 | 10 STARDUST DR. DORCHESTER ONTARIO N0L 1G5

Submitted by: Elias Baribeau



TABLE OF CONTENTS

- CATEGORY 1**
 - Company Profile 04
 - Design Build Team 08
 - BD Team Org Chart 13

- CATEGORY 2**
 - Project Examples & References 15
 - Staff CV's 20

- CATEGORY 3**
 - Project Approach 22
 - Quality Control 23
 - Value Added Features 24
 - Renderings and Drawings 25
 - Exclusions 27

- CATEGORY 4**
 - Project Schedule 29

- APPENDIX**
 - Staff CV's 30



CATEGORY 1

Company Info &
Design-Builder's Team

CATEGORY 1
COMPANY PROFILE



History

Since 1987, Baribeau Construction has been building a name of integrity and expertise in construction project management. Founding President Jack Baribeau has built a team of experienced and knowledgeable Construction Professionals who are ready to complete your next ICI project.

Located in Dorchester, ON and serving from Sarnia to Guelph, our team provides personalized service that first focuses on establishing trust and open lines of communication to ensure each project meets its key objectives.



18 Full-Time Staff

Executive Management:

- Jack Baribeau - Founding President
- Elias Baribeau - VP Operations
- Jacob Baribeau - VP Business Development

Office Staff: Project Manager, Project Coordinator, Accountant, Bookkeeper

Field Staff: Site Supervisors, Site Foreman, Carpenters, Skilled Labourers, General Labourers



Experience

The Baribeau Construction team has built their experience on the mantra, “learn by doing, systemize the process, then teach others”. Jack started in framing and learned how to build before moving into construction management, design, and then to project management. The team has built on that knowledge to offer a wide range of services in the ICI construction market for public and private clients. The key to our success is rooted in our values of doing the right thing, embracing the challenge, and being client focused. Some of the recent industrial projects Baribeau Construction has worked on include the list below:

Recent Projects:

- | | |
|------------------------------|----------------------------------|
| Mount Salem Christian School | BOS Innovations |
| A&L Labs | Exhaust Direct |
| Elgin Innovation Centre | Erie Electric Motors |
| Pink Precast Concrete | Mitchell's Soup |
| Sante Manufacturing | Stein Industries |
| PakFab Solutions | Old Imperial Farmers' Market |
| Motif Labs | St. Thomas-Elgin Social Services |
| Planet Shrimp | Ingersoll Fusion Centre |
| Whitecrest Mushrooms | EIC - Office Renovation |
| Pet Valu Aylmer | Many more..... |
| Ingersoll Town Hall | |
| Indiva | |

CATEGORY 1
OUR SERVICES



CONSTRUCTION MANAGEMENT

A collaborative (Cost+) delivery model where we manage and execute the physical construction of the project and provide budgetary, schedule, and constructability consultation during the design phase.



PROJECT MANAGEMENT

We manage the project (Cost +) from initial idea conception, through design, permitting, and construction all the way to final inspections and building hand over. Ideal for multi-phased and complex projects or projects that require speed and flexibility



DESIGN-BUILD

In collaboration with a design team, we design and build the structure under a single contract for simpler builds or two contracts for complex designs. Referred to as "Progressive Design-Build"



GENERAL CONTRACTING

Traditional fixed price or T&M contracting for large and small projects.



CATEGORY 1
FIELD TEAM CORE COMPETENCIES



DEMO

- Non-Heavy Equipment Demolition
- Asbestos Abatement



FRAMING

- Wood Framing
- Steel Stud Framing



SIDING

- Commercial Siding
- Steel Siding
- Vinyl Siding
- PVC Siding
- Stone Veneer Siding



DOOR & WINDOW SYSTEMS

- Doors
- Windows
- Hardware



DRYWALL BOARDING

- Drywalling
- Mud and Tape
- ACT



CATEGORY 1

ASSOCIATIONS & AFFILIATIONS

07

CANADIAN CONSTRUCTION ASSOCIATION

[Canadian Construction Association - CCA \(cca-acc.com\)](http://cca-acc.com)

FAMILY BUSINESS INSTITUTE

[The Family Business Institute | Family Business Institute](#)

ST. THOMAS AND DISTRICT CHAMBER OF COMMERCE

<https://www.stthomaschamber.on.ca/>

LONDON DISTRICT CONSTRUCTION ASSOCIATION

[Contact Us - London and District Construction Association \(ldca.on.ca\)](http://ldca.on.ca)

FAMILY ENTERPRISE CANADA

[The Family Business Community | Family Enterprise Canada](#)

CFIB

[Canadian Federation of Independent Business | CFIB \(cfib-fcei.ca\)](http://cfib-fcei.ca)

COMPANY LICENSES & CERTIFICATIONS

- GOLD SEAL EMPLOYER
- GOLDSEAL PROJECT MANAGER
- GOLDSEAL SITE SUPERVISOR
- GOLDSEAL FOREMAN
- REDSEAL CARPENTERS
- FIRST AID & CPR
- WSIB
- ASBESTOS & LEAD AWARENESS
- ASBESTOS ABATEMENT (TYPE 1 & 2)
- WORKING AT HEIGHTS
- MOBILE ELEVATED WORK PLATFORMS
- FORKLIFT OPERATOR SAFETY TRAINING

CATEGORY 1
DESIGN TEAM



DESIGN-BUILD CONTRACTOR

Baribeau Construction will act as the prime Design-Build contractor and will be responsible for the coordination of the design and the management of the construction.



MECHANICAL & PLUMBING ENGINEER

SBM will provide the mechanical and plumbing engineering. They will also be completing the energy modeling required by SB 10



BUILDING SUPPLIER

Steelway Building Systems will provide the shop drawing design and supply the building structure.



ELECTRICAL ENGINEER & DESIGN

Callidus Engineering will provide the electrical engineering and design.



STRUCTURAL ENGINEER & ARCHITECT

co-elevate Engineering will provide the structural engineering and architectural services.



About

Our design team will bring experience, knowledge, and specialized skills to your project. Whether it is lighting, fire protection, power, plumbing, HVAC or fire alarm, we will design the systems to suit your needs and budget. Our experience includes projects in residential, community gatherings, healthcare, industrial, institutional, transportation, and other sectors. Our wide range of experiences allows us to apply solutions across sectors. We use our experiences to be flexible with our designs, responding to you the client and your needs – looking beyond the standards of a given sector. With over 600 years of combined engineering and design experience, Callidus endeavours to bring our collective knowledge to every project.

Recent Firehall Projects:

- Bradford Fire Hall – I2n0 C2o1nstruction 2022
- Trent Hills EMS and Fire Hall Station -2021
- Malahide Fire Hall -2018
- Fire Hall #5 (London) Generator Replacement -2018 Perth County EMS and Fire Hall -2015
- Fire hall #6 (London) addition -2015
- Southwest Oxford Fire Hall - 2010
- Kerwood Fire Hall -2009

Core Values

At Callidus we value community – beyond just working together. We believe that this is a skill, that we cultivate in our firm. The cornerstone of our culture is caring for the people we work with – and that extends beyond our staff – it extends to our clients and all the partners we work with in construction projects. We work as a team through every stage of a project, accomplishing more and building a depth of relationship that translates into a positive experience for all involved.

Integrity is key in any relationship. We do what we say we will do. At Callidus, we hold ourselves to high standards and deliver on our commitments. When we fall short, we own our actions and find solutions – together.

At Callidus we say that “we don’t stand still”. We are ambitious, driven by a strong desire to always improve and and achieve optimal solutions for our projects.

We believe the following principles drive our success, and benefit you the client:
Work TOGETHER as a team – we accomplish more when we pull in the same direction
HAVE FUN – we are serious about having fun. Our balanced work environment attracts and helps keep great people and great clients.

More communication is better – Open communication is essential. We talk through problems to strengthen relationships.

Initi-action – This is a Callidus word for seeing what needs to be done, and doing it, without being asked to

Other Emergency Services Projects:

- Quinte West OPP Detachment -2020
- Renfrew OPP - 2019
- Teviotdale OPP Detachment -2012
- London EMS - 2013
- Fergus OPP Detachment -2010
- Barrie OPP Generator - 2007
- Geraldton OPP - 2007
- St Thomas EMS - 2005

Project References:

BRADFORD FIRE HALL

Project Manager: Jake Domm,
DOMM Construction LTD.,
519-665-7848

TRENT HILLS EMERGENCY RESPONSE CENTRE

Project Manager: Mark McIntosh
mcintoshm@northumb
erlandcounty.ca
905-372-3329 x2342



1385 N. Routledge Park, Unit 9
London, ON N6H 5N5
519-472-7640



About

Our core values are the guiding principles that help us achieve our purpose. With each new employee and every change in our processes, we have remained true to the core values that have guided us from the beginning.

People are happiest when their work, family and personal interests all aligned. As a result we encourage our employees to engage in community events, take classes outside of the workplace and balance their careers with other aspects of life.

Recent Projects:

- Element 5
- BOS Innovations
- Matthews Hall
- Centura London
- Mount Salem Christian School
- Westwood Power Centre
- Sunripe Market
- The Village of Glendale Crossing
- Northpoint II
- Owen Sound Gardens
- Milton Long Term Care

For more examples, please review our website at <https://www.co-elevate.ca/projects>

Structural Engineering Design and Drafting Services

Residential Projects:

- Design, drawing, and Ontario Building Code Review for Single, Multi-Unit, and Condominium Projects Lowrise and Midrise Steel, Concrete, and Wood Framed Buildings
- Renovations and Structural Rehabilitation
- Retaining Walls and Concrete Foundations
- Review, Analysis and Reporting for Insurance Companies
- Site Inspections

Specialized Projects:

- Specialized Structures and Foundations
- Concrete Pile Foundations
- Fire Stations
- High Mast Lighting Towers
- Highway Gantry Structures
- Analysis of Mining Headframes
- Shipping Container Homes
- Falsework and Shoring Design
- FEA analysis of the dynamic response of light-framed structures
- Engineering, Analysis, and Preparation of Documentation for CSA Approval of Manufactured Structures

Commercial Projects:

- Lowrise, Midrise, and highrise steel, Concrete, and Wood framed buildings
- Steel Stud Construction
- Shoring and Falsework
- Steel Connection and Misc. Metal Design
- Renovations and Structural Rehabilitation
- Develop Demolition Procedures
- Analysis and Review of Existing Structures
- Change of Use
- Review, Analysis and Reporting for Insurance Companies
- Site Inspections

Project References:

ELEMENT 5

Chris Latour
Chris@elementfive.co
548-888-8025

BOS INNOVATIONS

Ben Huigenbos
ben@bosinnovations.com

EXHAUST DIRECT

Pat Bruder
T: 519-247-3901

MOUNT SALEM CHRISTIAN SCHOOL

Tina Penner
T: 519-247-3901



(519) 681-6475 London, ON
www.co-elevate.ca
[info@co-elevate.ca.com](mailto:info@co-elevate.ca)



About

We are the Leading Canadian Manufacturer of Steel Building Systems. Founded in 1976, Steelway continues to be a family-owned and operated manufacturer of customized steel building solutions. A life-long passion for design and building along with an entrepreneurial spirit that has been passed down from a father to his sons is what defines our company culture. Honouring that legacy, our primary focus is fostering and maintaining positive long-term relationships with our clients, employees, and suppliers as well as the community in which we work and live.



FRAMING

Steelway buildings are completely customizable. Our flexible framing designs can accommodate unique building layouts that allow for future repurposing or expansion.

Our system is not limited to the standard grid or column spacing of conventional or traditional construction. Incorporate either clear span or multi-span options to accomplish unique requirements.



AESTHETICS

Any number of architectural finishing options are available to complement a steel building system. Choose specific areas of a building (street side, outside walls) to add architectural details, creating the most cost-effective use of a design. This flexibility allows customers to choose how their investment provides the best return.

Incorporate a variety of materials including steel, glass, aluminum, wood, masonry, block and precast concrete in endless combinations to meet requirements and achieve the desired personalized look.



THERMAL

Our building envelope provides thermal performance that meets all national and provincial energy codes but more importantly, customer needs. The energy efficiency of a steel building system creates lower operating costs to allow a greater return on your investment.

Our independently tested steel roofing and wall systems, when combined with the appropriate wall insulation systems, meet the required U values for energy efficiency.

Benefits of Steel

A steel building system (SBS) is a custom-engineered solution that optimizes and integrates framing, roofing and walls. Steel structures and components can help address many challenges that arise when building in urban centres. Engineered, prefabricated steel components can be rapidly installed reducing construction time and disruption on the site.

Testing our engineered building systems in field conditions worldwide is just one of the ways we ensure our commitment to high-quality, dependable building performance. Careful research and meticulous attention to detail throughout the years has allowed Steelway to refine our designs. The result, a product that delivers maximum efficiency, precise fit and peak performance, no matter the conditions.



Applications



COMMERCIAL



COMMUNITY/
GOVERNMENT



INSTITUTIONAL



MANUFACTURING



AGRICULTURAL



AVIATION/
HANGARS



INDUSTRIAL



RECREATIONAL



519-765-2244 Aylmer, ON
steelway.com
[Steelway on Linked-In](#)

SOUTHWOLD DESIGN-BUILD TEAM ORGANIZATION CHART

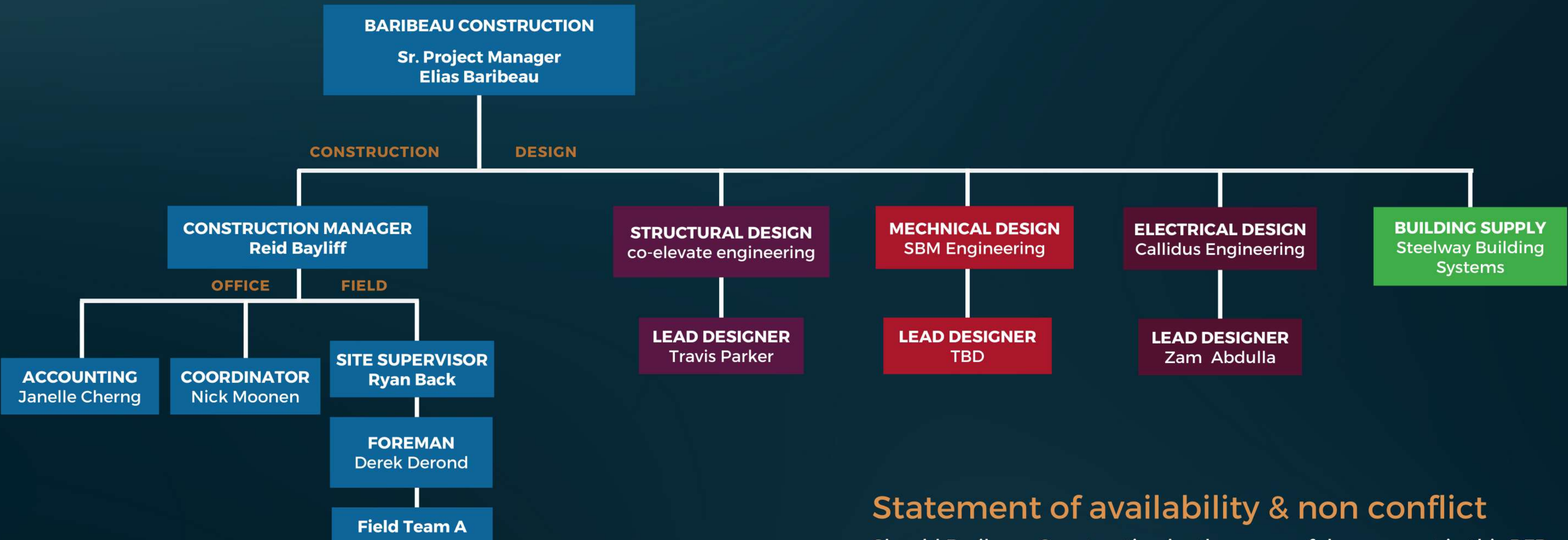

Statement of availability & non conflict

Should Baribeau Construction be the successful proponent in this RFP, we commit to keeping our staff listed in this organization chart available for the duration of the project. We also confirm that neither Baribeau Construction nor our staff do have any conflict of interest in regards to this project.

Elias Baribeau

YOUR TEAM AT BARIBEAU CONSTRUCTION

13

SR. PROJECT MANAGER

AS THE SR. PROJECT MANAGER, **ELIAS BARIBEAU** WILL ACT AS THE PROJECT LEAD. COORDINATING THE DESIGN TEAM, CONSTRUCTION TEAM, AND CLIENT COMMUNICATION. TIME ALLOCATED TO THIS PROJECT WILL VARY DEPENDING ON THE PROJECT PHASE BUT WE HAVE ALLOCATED 30% TIME TOWARDS THIS PROJECT.

CONSTRUCTION MANAGER

REID BAYLIFF, WILL ACT AS THE CONSTRUCTION MANAGER. WE HAVE ALLOCATED 60% OF HIS TIME TOWARDS THIS PROJECT,

PROJECT COORDINATOR

NICK MOONEN WILL BE ACTING AS PROJECT COORDINATOR ASSISTING THE CONSTRUCTION MANAGER WITH DAY TO DAY TASKS. HE WILL BE DEDICATING 50% OF HIS TIME TOWARDS THIS PROJECT DURING THE CONSTRUCTION PHASE.

FOREMAN

OUR CARPENTRY FOREMAN, **DEREK DEROND**, WILL BE ON SITE FOR A PORTION OF THE CONSTRUCTION PHASE TO MANAGE AND COMPLETE ANY WORK OUR CREWS WILL BE SELF-PERFORMING. IT IS ESTIMATED HE WILL BE ON SITE FOR 30% OF THE CONSTRUCTION PHASE.

SITE SUPERINTENDENT

RYAN BACK WILL BE ASSIGNED THE SITE SUPERINTENDENT. HE WILL BE DEDICATED TO THE SITE 100% DURING THE CONSTRUCTION PHASE.



CATEGORY 2

Project Examples

PROJECT EXAMPLE #1 INDUSTRIAL MANUFACTURING

Design Build - CCDC 14

Structure - Custom-engineered Metal Building (Steelway)

15



EXHAUST DIRECT

MANUFACTURING | LONDON, ON

In partnership with Steelway Building Systems, Baribeau Construction designed, permitted, and is nearing completion of this 14,488 sf manufacturing facility for Exhaust Direct. Substantial completion is expected by the end of April 2024.

The design includes a 1,800 sf mezzanine, two loading docks, large over head doors, 22' clear ceiling space, administration space, and a timber framed entrance.

Design Team:

- Baribeau Construction
- co-Elevate Engineering
- Balan Engineering
- Callidus Engineering
- Steelway Building Systems

Client: Pat Bruder - pat@exhaustdirect.ca



\$2.9M

Final
Contract
Value

**John
Harder**

Site
Supervisor

**14,488
sq'**

Final
Building
Size

**Dave
Miller**

Project
Manager

PROJECT EXAMPLE #2 INDUSTRIAL MANUFACTURING

Project Management / Construction Management
Structure: Pre-engineered Metal Building (Steelway)

16



BOS INNOVATION

INDUSTRIAL | DORCHESTER, ON

Baribeau Construction was engaged by BOS Innovations initially to construct a new office and fabricating shop for their growing business. BOS's operation continued to thrive and Baribeau Construction completed phase 2 and phase 3 additions for the facility. Baribeau Construction was hired as the prime consultant and completed the project on a Project Management/Construction Management contract. The final phase of the project was completed in 2018 and brought the total building size to approximately 38,000 sq'.

Design Team:

- MC Engineering
- Callidus Engineering
- Baribeau Construction
- Steelway Building Systems

Client: Ben Huigenbos - ben@bosinnovations.com



\$6M

Final
Contract
Value

**John
Harder**

Site
Supervisor

**38,000
sq'**

Final
Building
Size

**Elias
Baribeau**

Project
Manager

PROJECT EXAMPLE #3 COMMERCIAL LABRITORY

Contract Style - CCDC 5B
Structure - Conventional Steel

17

A&L LABS

MEDICAL | LONDON, ON



We worked with A&L Labs in 2014 for their first addition and they approached us again in 2021 when they had outgrown the space and were ready to build a second addition. The addition consisted of approximately 9,000 sq' of commercial office space and laboratory space. As this was an expansion of their current occupied facility, additional safety and environmental protections were put in place to ensure the organization could continue operating while work was taking place. We managed this project through multiple covid slow downs but maintained schedule. Unavoidable equipment delays caused substantial completion to miss the mark by several weeks.

Design Team:

- Baribeau Construction
- A+LiNK Architecture
- Callidus Engineering
- co-Elevate Engineering
- Driven Engineering

Client: Bob Munro - BMunro@alcanada.com

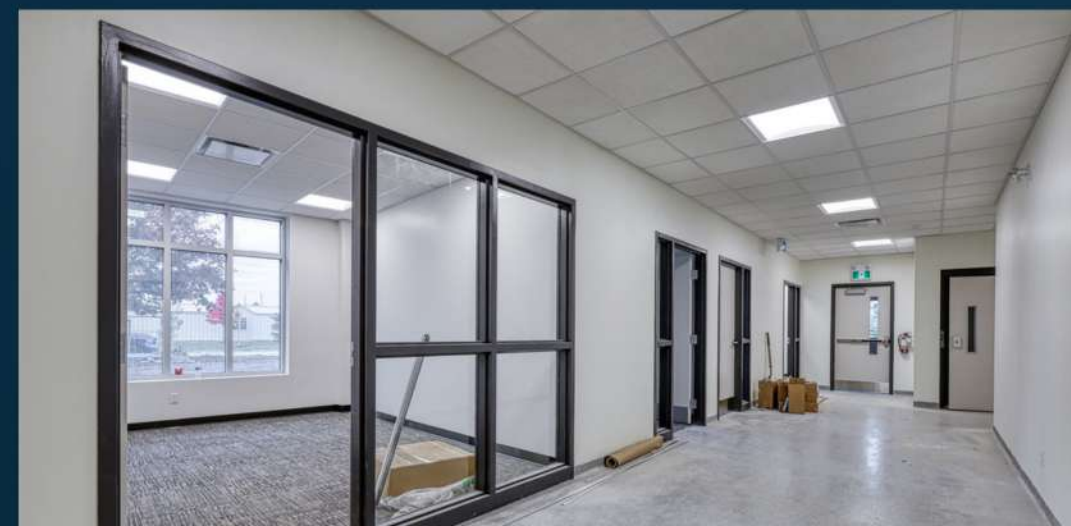

\$3.3m

Final Contract Value

Sept 13, 2022

Completion Date

9,000 sq'

Renovation Area

Reid Bayliff

Project Manager

PROJECT EXAMPLE #4 PRIVATE SCHOOL

Contract Style - CCDC 5B

Structure - Wood, Steel, Masonry, and Precast Concrete

MOUNT SALEM CHRISTIAN SCHOOL

INSTITUTIONAL | MOUNT SALEM, ON

18



The Mount Salem Christian School engaged Baribeau Construction to lead the planning and coordination of a new 38,104 square foot school for children from Kindergarten to Grade 8. Longevity and practicality were the primary elements that drove the design. By consulting local "Trade Champions" during the design process, the team specified many elements that could be constructed affordably while incorporating some of the toughest building materials where abuse is inevitable. The design took into consideration the future growth of the school and planned for a 17,000 square foot addition. The project broke ground in 2023. Today it is under budget and ahead of schedule with completion expected summer 2024.

Design Team:

- Baribeau Construction
- Henry Swinkels Architect
- WS Engineering
- co-Elevate Engineering
- Driven Engineering

Client: Tina Penner - jtctjpenner@yahoo.ca

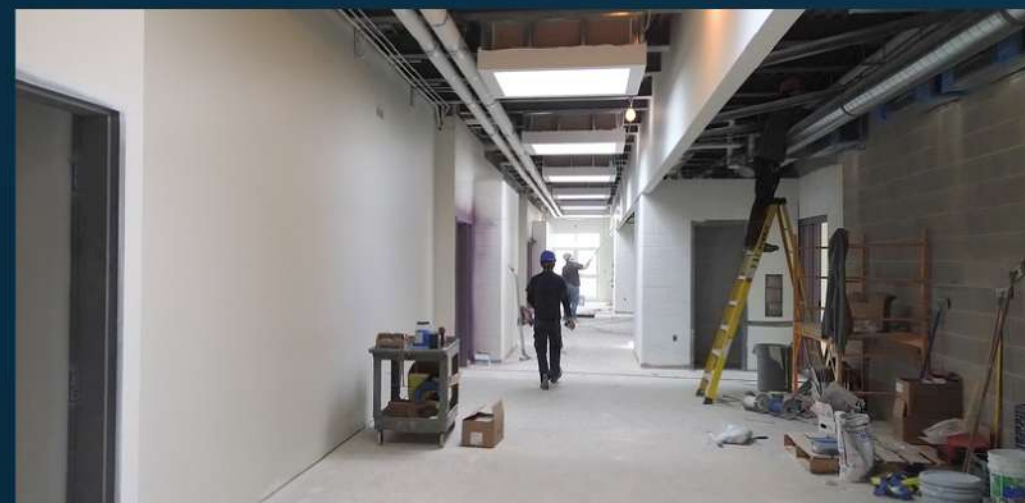

\$9.4m

Projected
Final Budget

**June 10,
2024**

Expected
Completion
Date

**38,104
sq'**

Building
Size

**Reid
Bayliff**

Project
Manager

PROJECT EXAMPLE #5 COMMUNITY MARKET

Contract Style: Construction Management - Custom Contract
Structure - Wood and Timber Construction

OLD IMPERIAL FARMERS' MARKET

COMMERCIAL | AYLMEER, ON

19



The Old Imperial Farmers' Market retained Baribeau Construction to assist with creating a space suitable to host a sustainable year-round market focused on supporting local vendors and artisans in the Aylmer Area. Using a custom Construction Management contract, Baribeau Construction led the complete overhaul of an unserviced warehouse previously operated by Imperial Tobacco. The renovation incorporated the old timber structure while upgrading infrastructure elements that were required to bring the building up to code for the change of use. The heavy timber canopy was self-performed by our carpentry team.

Design Team:

- Baribeau Construction
- A+LiNK Architecture
- Callidus Engineering
- DC Buck

Client: Terry Dueck - Terry@OIFM.ca



\$1,028,764

Final Contract Value

August 17, 2022

Substantial Completion

18,813 sq'

Renovation Area

Reid Bayliff

Project Manager

STAFF CV'S

STAFF CV'S HAVE BEEN INCLUDED IN THE APPENDIX





CATEGORY 3

Project Approach

PROJECT APPROACH	22
QUALITY CONTROL	23
VALUE ADDED FEATURES	24
RENDERINGS AND DRAWINGS	25
EXCLUSIONS	27

PROJECT APPROACH: 6-STEP PROCESS

22

1. DESIGN-BUILD CONTRACT

Should Baribeau Construction be awarded this project, our first step would be to meet the outlined conditions in section 2.11 pertaining to the successful bidder and then enter into a CCDC-14 contract.

2. DESIGN

By nature of the design-build RFP process, the preliminary coordination of our design team has already begun. Our design team has familiarized themselves with our critical sub-trades and preliminary communication have taken place. Bi-weekly team meetings will be implemented to ensure the design schedule is properly maintained.

3. INITIAL PROCUREMENT & SHOP DRAWING REVIEW

Should the contract be awarded and conditions met, a review of long lead time items would happen immediately with the design team. Steelway's team of engineers will begin generating shop drawings for review in order to get the building into their manufacturing schedule. Any other equipment or materials risking the critical path, would be ordered in consultation with the design team.

4. PERMITTING

Since R.J. Burnside & Associates Limited will be taking responsibility Site Plan Approval, we will focus on applying and obtaining the building permit. In our schedule, we have Aug 24, 2024 scheduled for the permit submission milestone. This will give us sufficient time to address any concerns and meet our scheduled ground breaking date of Oct 03, 2024

5. CONSTRUCTION

Once we have broken ground, our site supervisors will be providing daily/weekly/monthly reports to the project manager to ensure that progress is tracking according to schedule. Bi-weekly reports are sent to the client showing progress and identifying any potential challenges.

Should challenges arise, our experienced Design-Build team will meet to provide a solution that puts the client's needs first.

6. CLOSE OUT

Upon substantial completion, our team will complete final letters of inspection with consultants and the CBO, a walk through with the owner, arrange for equipment training, prepare as-built drawings and warranty documents, and finally we will compile documents into a USB stick and/or binder for client storage.

QUALITY CONTROL

23

1 QUALITY CONTROL FOR SUB-TRADE CONTRACTS

- a. All trades will be pre-approved trades (no public tendering). The trade tender lists are created from Baribeau Construction's list of approved sub-trades ensuring control over who is allowed on site.
- b. Detailed instructions are created for each tender to ensure bidders have clear scopes of work.
- c. We stay in communication with tendering trades to ensure bids are received from each tendering at closing.
- d. All quotations are reviewed at tender closing to ensure compliance and eliminate overlap.

2 QUALITY CONTROL OVER THE WORK OF THE SUB-TRADES

- a. Site Supervisor processes including daily walk through, daily journal, and weekly foreman meetings to ensure quality and coordination on the job site.
- b. Sub-trade pre-qualification, historical experience, and background checks ensure only capable trades who are able to meet the schedule, become part of the project team.

3 PROJECT CONTROL OVER THE SCHEDULE

- a. A preliminary schedule has accompanied this proposal. As the design progresses, the budget and schedule are updated to stay in synergy with the design.
- b. Trades must commit to the project schedule prior to being awarded the contract.
- c. Baribeau Construction has its own carpentry and labourer crew. This provides flexibility to assist in pushing schedules forward if unforeseen delays arise.

4 PROJECT CONTROL OVER MATERIAL DELIVERY AND LEAD TIMES

- a. Regular communication with suppliers and sub-trades helps us monitor material lead times. The recent instability of the supply chain has made this a key part of our process in controlling the project schedule.
- b. Lead times are tracked and integrated into the project schedule.
- c. Critical path items, such as, HVAC, the building system, or electrical transformers, are prioritized early in the pre-construction phase to minimize their schedule impact.
- d. Baribeau Construction has built strategic supplier relationships with the major building component suppliers including steel, masonry, flat roof installers, aluminum glazing, among others.

5 CONSTRUCTION MANAGEMENT SYSTEMS UTILIZED TO TRACK PROJECT PROGRESS

- a. MS Project is utilized to optimize sequencing, track progress, and communicate any changes to the project schedule.
- b. SiteMax is utilized to assist with daily logs, safety, and overall communication with the project team.
- c. The Baribeau Way is a proprietary system used to manage the operations of a project. This system guides the PM through the construction process and ensures critical steps are not missed.

VALUE ADDED FEATURES

24

Upon review of the preliminary design, the RFP documents, and minutes from council meetings, our interpretation is that the primary purpose of this building is to provide a highly functional and durable building at a price tag as affordable as possible. Our team toured the municipal works building in Thames Centre and discussed with their staff components that have functioned well and others that have failed. Taking this information into our design methodology, we partnered with Steelway Building Systems to propose a custom metal building with value added features to ensure a building that will perform with efficacy, longevity, and be low maintenance. Below is an outline of the value added elements we have proposed.

Aesthetics Upgrades

1) Main Entrance

We included a Versetta stone veneer to highlight the entrance and help with wayfinding to the front door. We included an aluminum front entrance & hollow metal frames for the windows.

2) Signage

To better highlight the signage, we specified back-lite, 3D lettering and allowed for signage with municipal logo.

3) Siding Selection

We have specified Stormseal siding that comes standard with most Steelway Building Systems.

4) Landscaping Option

We provided an option to include a green space near the main entrance for landscaping and as an employee amenity space.

Safety Upgrades

5) Wall Sconces

Sconces have been added to allow for adequate site lighting around the building.

6) Concrete Sidewalk Option

We included a sidewalk to provide a safe pathway from the main parking to the front entrance.

7) Protective Bollards

Total of 32x bollards to protect the overhead doors on either side of the building.

8) Fiberglass Service Pit Covers

The Thames Centre staff highly recommended we add pit covers to increase worker safety. We have included that recommendation in our proposal.

9) Underground Electrical Service

We have designed the electrical service to be installed underground rather than overhead. This will increase safety by eliminating risk of trucks coming into contact with live wires.

Quality Upgrades

10) Masonry Block Walls

Masonry block walls have been included to separate the shop from office and for sign storage 109, oil storage 113, and Mech Rm 114. Block walls came highly recommended by Thames Centre Staff.

11) Standing Seam Metal Roof

A standing seam metal roof is a superior roof spec that comes with manufacture's 40 year Limited warranty.

12) Stainless Steel Hand Wash Basin

The Thames Centre staff preferred a wash basin for handwashing as opposed to individual sinks. We included a stainless steel basin.

13) Metal Gear Lockers

We have included the metal gear lockers at 24" wide per the RFP.

14) Interior Metal Liner

24g steel siding has been included as a liner throughout the interior of the building. Standard gauge is 28g. We upgraded the gauge to increase durability of the final product.

15) Custom Metal Building

Supplied and designed by Steelway Building Systems this structure is a quality system that will stand the test of time.

16) Concrete Apron

We included a 4'x100'x6" concrete apron on east and west side elevations to protect the asphalt from damage due to dry steering. Upgrade reflected on drawing SIT1



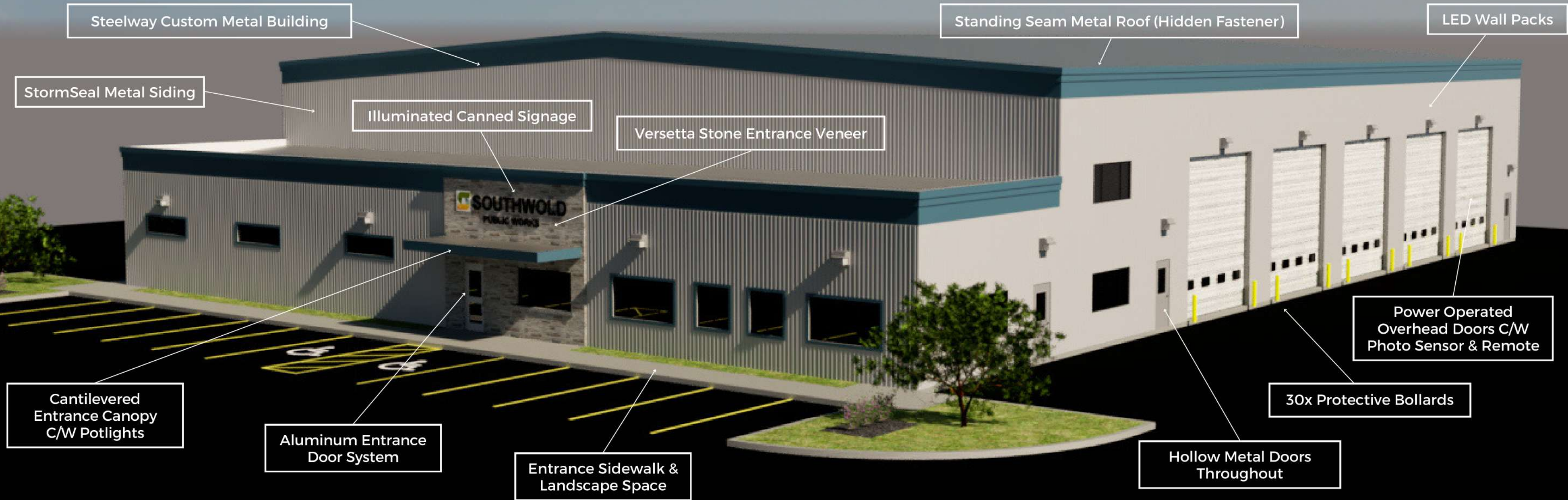



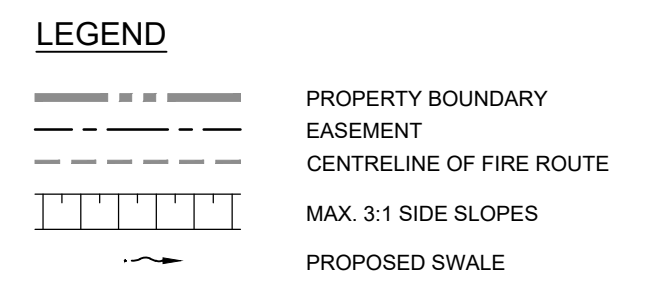
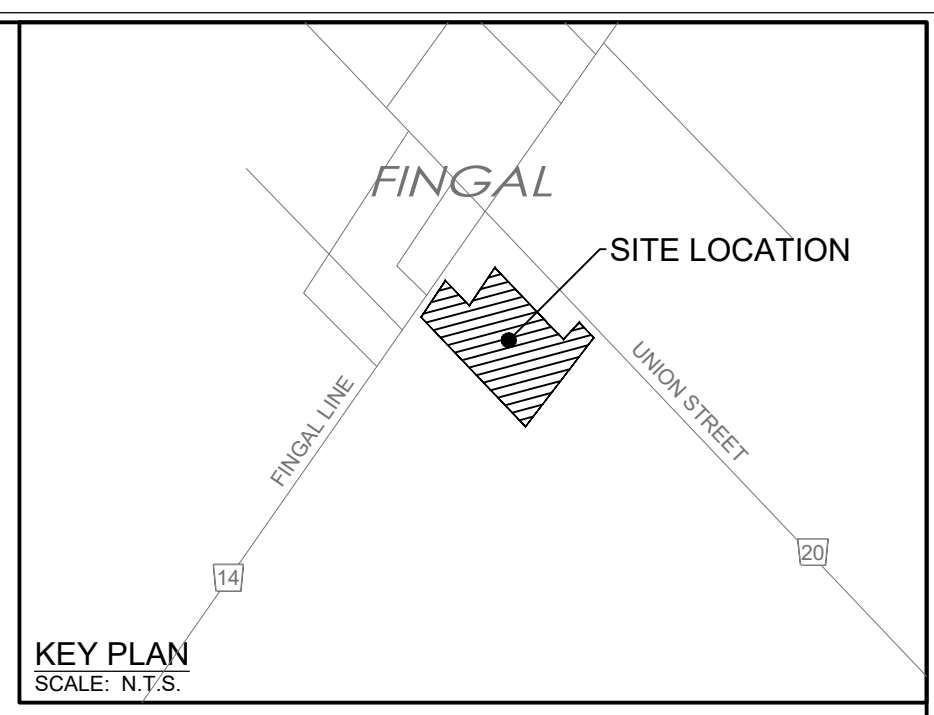

BARIBEAU CONSTRUCTION
EST. 1987

Vision Builders.

Project Management | Construction Management | Feasibility Studies | Design-Build | Industrial | Commercial | Institutional

Notes:

Optional Sidewalk and Landscape Areas:
We have proposed an option to add a sidewalk and landscaping area to the front entrance. The option would push building south 8ft and reduce the gravel storage space. This option is reflected on the rendering.

Concrete Apron:
4'x100'x6" concrete apron on east and west side elevations to protect the asphalt from damage due to dry steering.

Exclusions:

- Used Oil Tank
- All process equipment
- Removal of fuel depot

Notes

1. This drawing is the exclusive property of R. J. Burnside & Associates Limited. The reproduction of any part without prior written consent of this office is strictly prohibited.
2. The contractor shall verify all dimensions, levels, and datums on site and report any discrepancies or omissions to this office prior to construction.
3. This drawing is to be read and understood in conjunction with all other plans and documents applicable to this project.

NOT FOR CONSTRUCTION

No.	Issue / Revision	Date	Auth.
1	ISSUED FOR CLASS D COST ESTIMATE	22/06/08	FG
2	ISSUED FOR 50% DESIGN SUBMISSION	22/07/25	FG
3	ISSUED FOR 90% DESIGN SUBMISSION	22/10/24	FG
4	ISSUED FOR SECOND SUBMISSION	22/11/07	FG
5	ISSUED FOR THIRD SUBMISSION	22/12/14	FG



BURNSIDE

R. J. Burnside & Associates Limited
35 Perry St.
Woodstock, Ontario, N4S 3C4
telephone: (519) 344-5331
fax: (519) 271-3790
web: www.rjburnside.com

Client
TOWNSHIP OF SOUTHWOLD
35663 FINGAL LINE
FINGAL, ONTARIO
N0L 1K0

Drawing Title
SOUTHWOLD PUBLIC WORKS BUILDING ADDITION
SITE PLAN

Drawn	Checked	Designed	Checked	Date	Drawing No.
BF	FG	BF	FG	22/07/25	
Project No. 054978	Contract No. 300054978	Revision No. 0			

Scale: 1:500

0 5.0 10.0 20.0 30.0m

SIT1

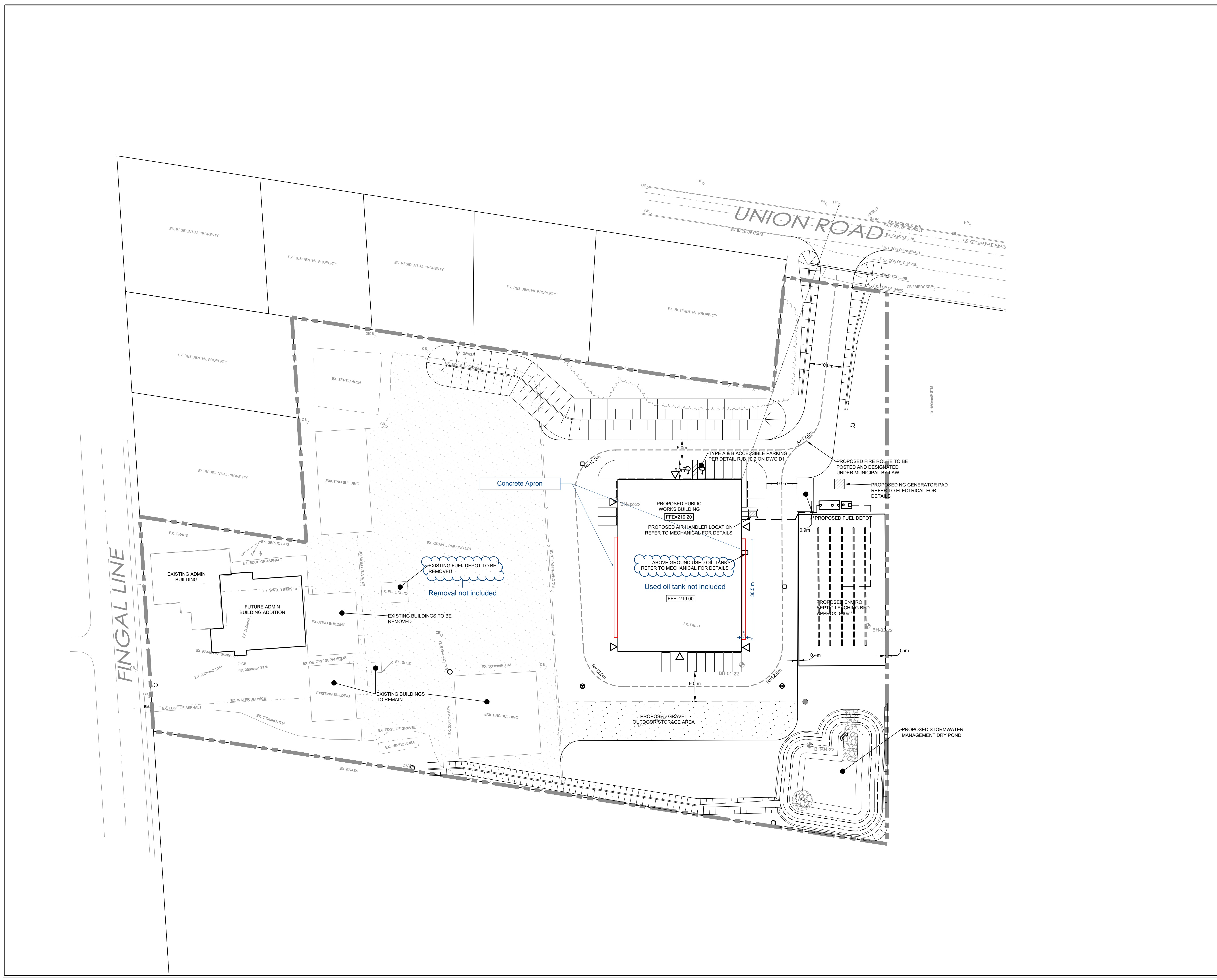



- GENERAL NOTES:**
1. ALL WORK SHALL BE CARRIED OUT IN COMPLIANCE WITH THE APPLICABLE HEALTH AND SAFETY ACT AND REGULATIONS FOR CONSTRUCTION PROJECTS.
 2. ALL THE CONSTRUCTION WORK FOR THIS PROJECT SHALL COMPLY WITH THE STANDARD DRAWINGS AND SPECIFICATIONS OF THE TOWNSHIP OF SOUTHWOLD AND THE ONTARIO PROVINCIAL STANDARDS AND SPECIFICATIONS.
 3. THE CONTRACTOR IS ADVISED THAT WORKS BY OTHERS MAY BE ONGOING DURING THE PERIOD OF THIS CONTRACT. THE CONTRACTOR SHALL COORDINATE CONSTRUCTION ACTIVITIES WITH ALL OTHER CONTRACTORS AND PREVENT CONSTRUCTION CONFLICTS.
 4. THE INFORMATION SHOWN FOR EXISTING UTILITIES WAS PROVIDED BY OTHERS. THE CONTRACTOR IS RESPONSIBLE FOR LOCATING AND PROTECTING ALL UTILITIES DURING CONSTRUCTION. ALL EXISTING UTILITIES MUST BE LOCATED AND VERIFIED BY EACH UTILITY PRIOR TO COMMENCEMENT OF WORK. ANY VARIANCE IS TO BE IMMEDIATELY REPORTED TO THE ENGINEER. LOST TIME DUE TO FAILURE OF THE CONTRACTOR TO CONFIRM UTILITY LOCATIONS AND NOTIFY THE ENGINEER OF CONFLICTS PRIOR TO CONSTRUCTION WILL BE AT THE CONTRACTOR'S EXPENSE.
 5. ROAD OCCUPANCY/ACCESS PERMIT MUST BE OBTAINED 48 HOURS PRIOR TO COMMENCING ANY WORKS WITHIN THE MUNICIPAL ROAD ALLOWANCE.

- LOT GRADING:**
1. MAXIMUM LOT COVERAGE AND ALL SETBACKS SHALL BE IN ACCORDANCE WITH CURRENT MUNICIPAL BY-LAWS. IF NECESSARY, THE OWNER SHALL VERIFY THE LOCATION OF ANY SETBACKS ON-SITE WITH THE APPROPRIATE AGENCIES OR MUNICIPAL REPRESENTATIVE.
 2. IT SHALL BE ASSUMED THAT THE GRADIENT BETWEEN SUCCESSIVE PROPOSED LOT ELEVATIONS SHOWN ON THE PLAN IS EITHER CONSTANT, OR AT THE GRADIENT SPECIFIED.
 3. ALL IMPERVIOUS SURFACES SHALL BE GRADED TO ENSURE POSITIVE DRAINAGE AND GRADIENT AWAY FROM ANY BUILDINGS AND ALONG THE COURSE OF ANY WALKWAYS OR FROM ANY LARGER IMPERVIOUS AREAS INCLUDING NO PONDING OF WATER WITHIN THESE AREAS. THE CONTRACTOR SHALL NOTIFY THE ENGINEER AND THE OWNER OF ANY CONCERNS WITH THE PROPOSED ELEVATIONS AND GRADIENTS PRIOR TO PLACEMENT OF ANY GRANULARS, ASPHALT, PAVING STONE OR CONCRETE TO ALLOW FOR A THOROUGH ON-SITE REVIEW AND ADJUSTMENT (IF ANY). ANY PONDING ON IMPERVIOUS SURFACES SHALL BE DEEMED A DEFICIENT ITEM. THE AFFECTED SURFACE SHALL BE REMOVED AND REPLACED BY THE CONTRACTOR AND AT THE CONTRACTOR'S EXPENSE; THE EXTENT OF THE AREA TO BE REMOVED AND REPLACED SHALL BE AS DETERMINED BY THE OWNER OR THE ENGINEER.
 4. THE CONSTRUCTION SHALL INCLUDE THE ESTABLISHING OF A PERMANENT VEGETATIVE COVER OVER ALL AREAS EXCEPT THE DRIVEWAYS, PARKING AREAS AND THE BUILDINGS. THIS COVER WILL FILTER THE RUNOFF AND REDUCE POTENTIAL SEDIMENTATION. THE VEGETATED AND LANDSCAPED AREAS ON EACH LOT AND THE GRASSED SWALES THAT CONDUCT SURFACE RUNOFF WILL ALSO ENHANCE WATER QUALITY BY MEANS OF VEGETATIVE FILTERING.
 5. EXISTING VEGETATION ON SITE TO BE REMOVED AND DISPOSED OF OFF SITE BEFORE LOT GRADING WORK IF REQUIRED.
 6. ALL DOWNSPOUTS, SUMP PUMP AND OTHER DRAINAGE DISCHARGE POINTS SHALL DISCHARGE ON TO A SPLASH PAD OR AS NOTED ON THE DRAWING.
 7. ALL PROPOSED LOT ELEVATIONS REPRESENT EITHER FINISHED ASPHALT, GRANULARS OR GROUND.
 8. DRIVEWAYS AND PARKING AREAS ARE RECOMMENDED (OR AS PER A GEOTECHNICAL REPORT) TO BE A MINIMUM OF:
 - GRANULAR:
 - 150 mm GRANULAR A (MINIMUM)
 - 300 mm GRANULAR B (MINIMUM)
 - ASPHALT:
 - 40 mm HL3 (MINIMUM)
 - 60 mm HL8 (MINIMUM)
 9. IT IS RECOMMENDED THAT THE CONTRACTOR RETAINS A GEOTECHNICAL CONSULTANT FOR THE TESTING OF ALL GRANULARS AND ASPHALT.
 10. RECOMMENDED MINIMUM SEPARATION BETWEEN FINISHED GROUND AROUND THE BUILDING ENVELOPE AND THE TOP OF THE FOUNDATION WALL IS 200 MILLIMETRES. THE ACTUAL MINIMUM AS PER SECTION 9.15.4.3 (1) O.B.C. IS 150 MILLIMETRES OR 200 MILLIMETRES AS PER SECTION 9.27.2.2 (1) O.B.C.

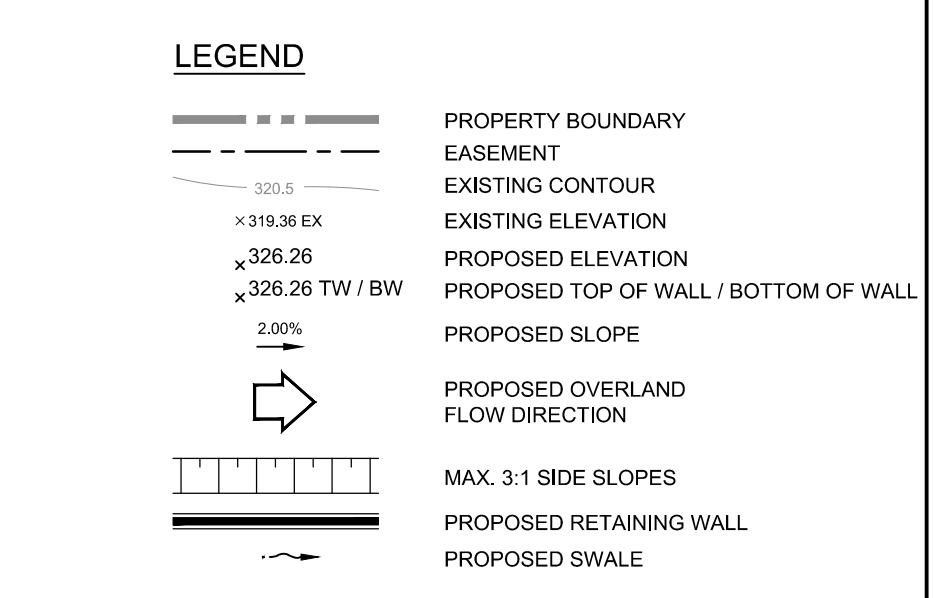
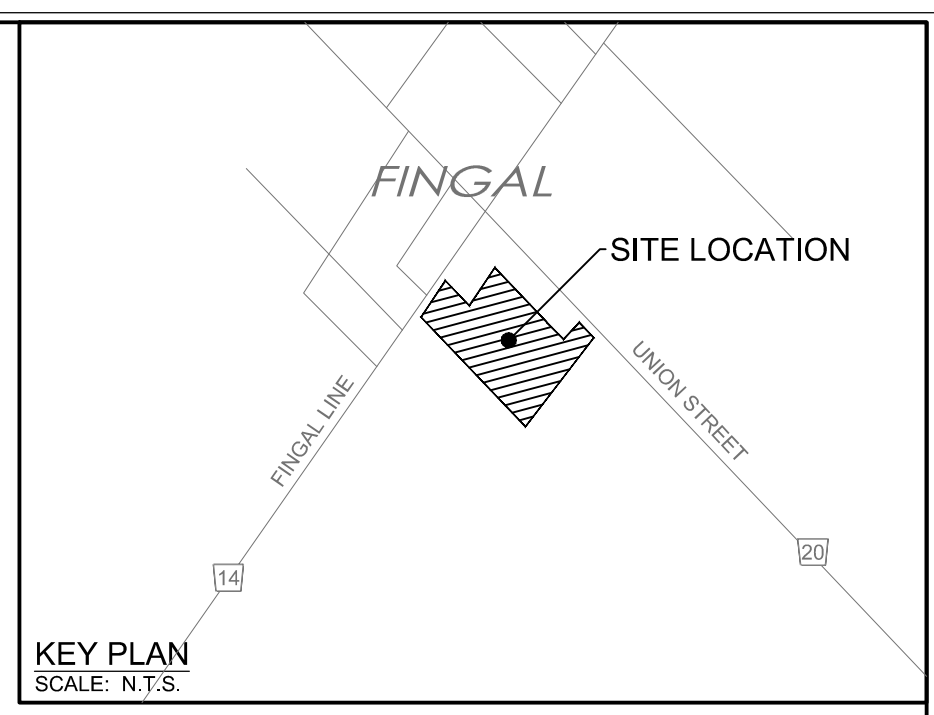

BARIBEAU CONSTRUCTION
 Vision Builders.
 Project Management | Construction Management | Feasibility Studies | Design-Build | Industrial | Commercial | Institutional

Notes:
 No additional options or changes proposed.

SURVEY CREDIT:
 LEGAL SURVEY PROVIDED BY: ARCHIBALD, GREY AND MCKAY LTD., ONTARIO LAND SURVEYORS. COMPLETED JAN. 25TH 2022
 TOPOGRAPHIC SURVEY PROVIDED BY: SPIRIT ASSOCIATES LTD. 2021 / R.J. BURNSIDE & ASSOCIATES LIMITED 2022
 BENCHMARK No. 1
 TOP OF WATER VALVE LOCATED AT NORTH WEST CORNER OF EXISTING EDGE OF ASPHALT AT FINGAL LINE ENTRANCE. ELEVATION = 217.142m
 BENCHMARK No. 2
 NAIL IN HYDRO POLE ON WEST SIDE OF UNION ROAD APPROXIMATELY 100m SOUTH OF SOUTH PROPERTY LINE MARKED WITH ORANGE SURVEY TAPE. ELEVATION = 219.338m

NOTES:
 1. This drawing is the exclusive property of R. J. Burnside & Associates Limited. The reproduction of any part without prior written consent of this office is strictly prohibited.
 2. The contractor shall verify all dimensions, levels, and datums on site and report any discrepancies or omissions to this office prior to construction.
 3. This drawing is to be read and understood in conjunction with all other plans and documents applicable to this project.

NOT FOR CONSTRUCTION

No.	Issue / Revision	Date	Auth.
1	ISSUED FOR CLASS D COST ESTIMATE	22/06/08	FG
2	ISSUED FOR 50% DESIGN SUBMISSION	22/07/25	FG
3	ISSUED FOR 90% DESIGN SUBMISSION	22/10/24	FG
4	ISSUED FOR SECOND SUBMISSION	22/11/07	FG
5	ISSUED FOR THIRD SUBMISSION	22/12/14	FG



R.J. BURNSIDE & ASSOCIATES LIMITED
 35 Perry St.
 Woodstock, Ontario, N4S 3C4
 telephone: (519) 341-5331
 fax: (519) 271-3790
 web: www.rjburnside.com

Client:
TOWNSHIP OF SOUTHWOLD
 35663 FINGAL LINE
 FINGAL, ONTARIO
 N0L 1K0

Drawing Title:
**SOUTHWOLD PUBLIC WORKS BUILDING
 ADDITION
 GRADING PLAN**

Drawn	Checked	Designed	Checked	Date	Drawing No.
BF	FG	BF	FG	22/07/25	
Project No.	Contract No.	Revision No.			
054978	300054978	0			
Scale	0 5.0 10.0 20.0 30.0m				
1:500					

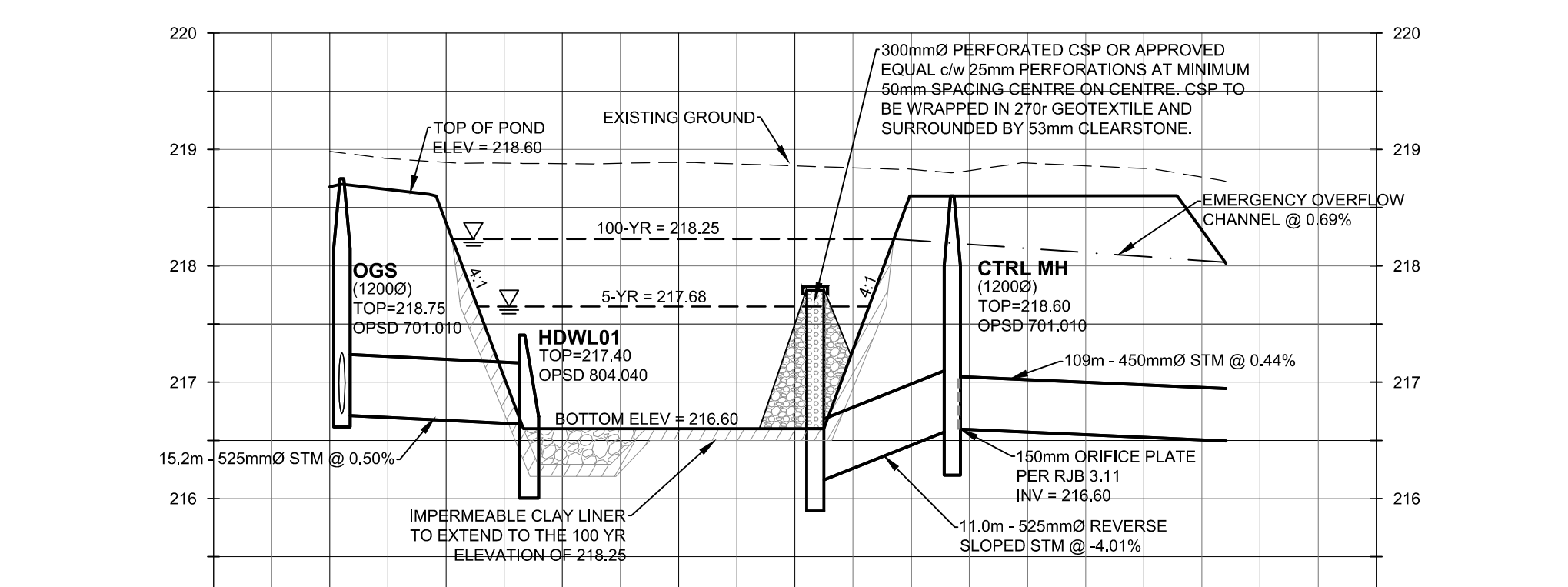

EXIST/PROP CENTERLINE ELEVATION	218.99	218.994	218.99	218.989	218.98	218.978	218.99	218.988	218.989	218.98	218.981	218.98	218.983	218.98	218.9836	EXIST/PROP CENTERLINE ELEVATION
CHAINAGE	0+000	0+010	0+020	0+030	0+040	0+050	0+060	0+070	0+080	0+090	CHAINAGE					

SECTION A-A
 SCALE H1:500 V1:50

File: I:\Projects\2022\22-07-25_Southwold-Public-Works-Building-Addition-Grading-Plan.dwg, Date: Printed: December 19, 2022, 5:15 PM

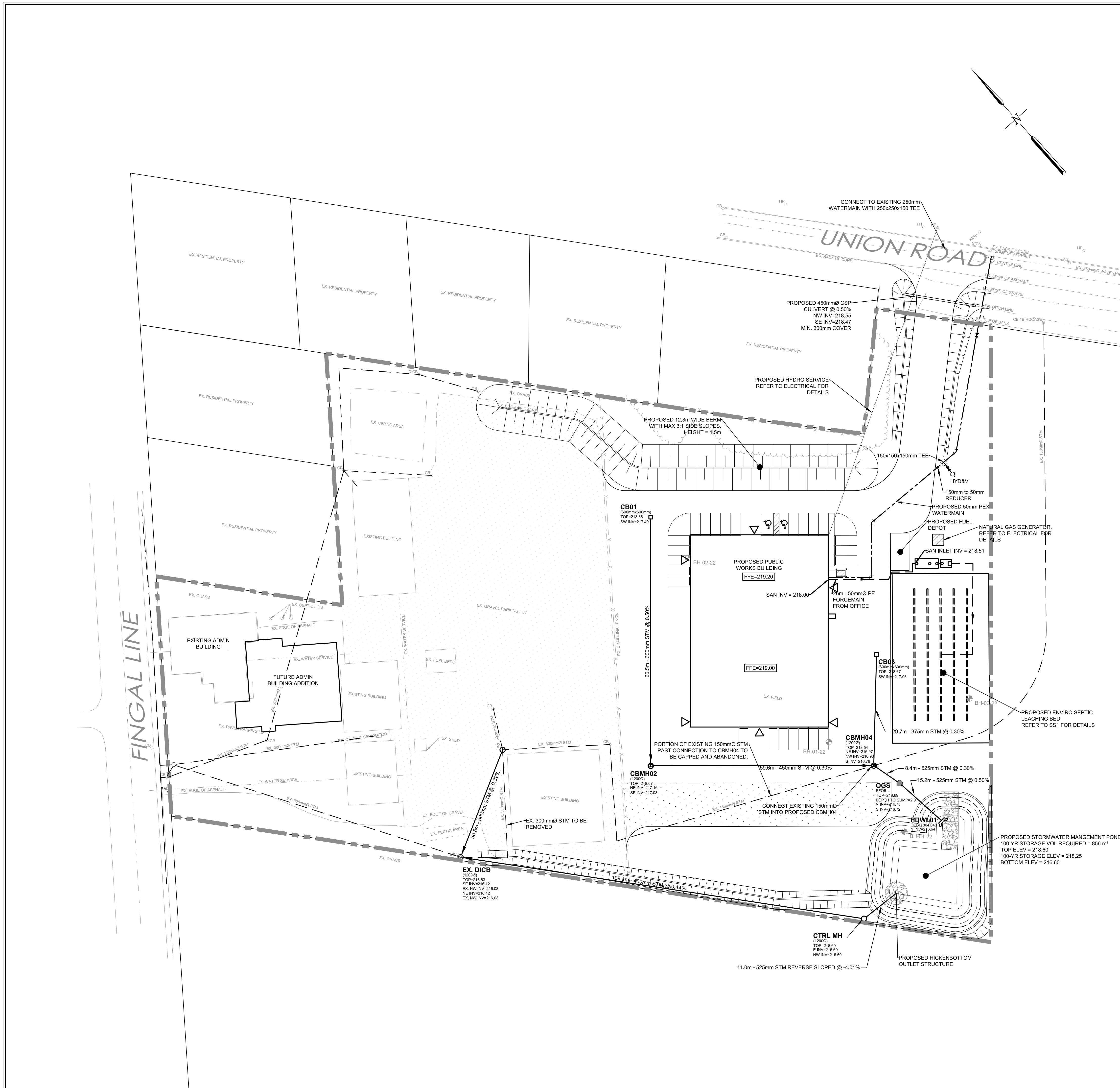

- GENERAL NOTES:**
1. ALL WORK SHALL BE CARRIED OUT IN COMPLIANCE WITH THE APPLICABLE HEALTH AND SAFETY ACT AND REGULATIONS FOR CONSTRUCTION PROJECTS.
 2. ALL THE CONSTRUCTION WORK FOR THIS PROJECT SHALL COMPLY WITH THE STANDARD DRAWINGS AND SPECIFICATIONS OF THE TOWNSHIP OF SOUTHWOLD AND THE ONTARIO PROVINCIAL STANDARDS AND SPECIFICATIONS.
 3. THE CONTRACTOR IS ADVISED THAT WORKS BY OTHERS MAY BE ONGOING DURING THE PERIOD OF THIS CONTRACT. THE CONTRACTOR SHALL COORDINATE CONSTRUCTION ACTIVITIES WITH ALL OTHER CONTRACTORS AND PREVENT CONSTRUCTION CONFLICTS.
 4. THE INFORMATION SHOWN FOR EXISTING UTILITIES WAS PROVIDED BY OTHERS. THE CONTRACTOR IS RESPONSIBLE FOR LOCATING AND VERIFYING ALL UTILITIES DURING CONSTRUCTION. ALL EXISTING UTILITIES MUST BE LOCATED AND VERIFIED BY EACH UTILITY PRIOR TO COMMENCEMENT OF WORK. ANY VARIANCE IS TO BE IMMEDIATELY REPORTED TO THE ENGINEER. LOST TIME DUE TO FAILURE OF THE CONTRACTOR TO CONFIRM UTILITY LOCATIONS AND NOTIFY THE ENGINEER OF CONFLICTS PRIOR TO CONSTRUCTION WILL BE AT THE CONTRACTORS EXPENSE.
 5. ROAD OCCUPANCY/ACCESS PERMIT MUST BE OBTAINED 48 HOURS PRIOR TO COMMENCING ANY WORKS WITHIN THE MUNICIPAL ROAD ALLOWANCE.

- WATERMAINS:**
1. WATERMAIN SHALL BE POLYVINYL CHLORIDE (PVC) CLASS 150 DR-18 PIPE MANUFACTURED TO AWWA C900-89 AND CSA CAN3 B137.3-M1986 WITH GASKETED BELL END CW #14 AWG SOLID COPPER TRACER WIRE.
 2. WATER SERVICE SHALL HAVE VERTICAL CLEARANCE OF 300mm OVER AND 500mm UNDER SEWERS AND ALL OTHER UTILITIES WHEN CROSSING. ALL WATERMAINS AND SERVICES SHALL HAVE 1.70m MINIMUM COVER.
 3. BEDDING FOR WATERMAINS SHALL BE AS PER OPSD 802.030.
 4. ALL WATERMAIN HORIZONTAL AND VERTICAL BENDS, JOINTS AND PLUGS TO BE MECHANICALLY RESTRAINED.
 5. ALL WATERMAIN STUBS SHALL BE TERMINATED WITH A PLUG AND 50mm BLOW OFF UNLESS OTHERWISE NOTED.
 6. HYDRANT AND VALVE TO BE AS PER OPSD 1105.010.
 7. ALL HYDRANT FLANGE ELEVATIONS TO BE INSTALLED 0.15m ABOVE PROPOSED FINISHED GRADE AT HYDRANT.
 8. BUILDING SERVICE VALVES TO BE 3.0m OFF THE FACE OF THE BUILDING.
 9. PROVISIONS FOR FLUSHING WATERMAINS MUST BE PROVIDED WITH A MINIMUM 50mm OUTLET FOR MAINS 100mm AND LARGER. FLUSHING POINTS MATCHING THE SIZE OF THE PIPE MUST BE PROVIDED AT THE END OF EACH COPPER MAIN. FIRE MAIN FLUSHING OUTLETS TO BE 100mm DIAMETER MINIMUM OR A HYDRANT. FLUSHING POINTS MUST BE HOSED OR PIPED TO ALLOW THE WATER TO DRAIN.
 10. ALL WATERMAINS SHALL BE HYDROSTATICALLY TESTED IN ACCORDANCE WITH LOCAL MUNICIPAL AND PROVINCIAL GUIDELINES UNLESS OTHERWISE DIRECTED. PROVISIONS FOR FLUSHING WATER LINE PRIOR TO TESTING, ETC. MUST BE PROVIDED.
 11. ALL PROPOSED WATER PIPING MUST BE ISOLATED FROM EXISTING MAINS IN ORDER TO ALLOW INDEPENDENT PRESSURE TESTING AND CHLORINATION.

- STORM AND SANITARY SEWERS:**
1. MANHOLES SHALL BE AS PER OPSD 701.010. FRAMES AND COVERS SHALL BE AS PER OPSD 401.010. SAFETY PLATFORMS TO BE INSTALLED WHERE DEPTH EXCEEDS 5.0m.
 2. SINGLE CATCHBASINS SHALL BE AS PER OPSD 705.010, WITH FRAMES AND COVERS AS PER OPSD 400.020. DOUBLE CATCHBASINS SHALL BE AS PER OPSD 705.020.
 3. CONCRETE PIPE SEWER BEDDING SHALL BE CLASS 'B' AS PER OPSD 802.030. PVC PIPE SEWER BEDDING SHALL BE CLASS 'B' AS PER OPSD 802.030. CSP PIPE SEWER BEDDING SHALL BE CLASS 'B' AS PER OPSD 802.030 TO TOP OF SEWER WITH A MINIMUM 300mm SAND COVER OVER PIPE. NATIVE BACKFILL TO BE COMPACTED TO A MIN. 98% STANDARD PROCTOR DENSITY.
 4. ALL STORM SEWER PIPES UP TO 450mm DIA. SHALL BE PVC SDR-35 OR APPROVED EQUIVALENT. ALL STORM SEWER PIPES 525mm DIA. AND LARGER SHALL BE CONCRETE AND EQUAL TO C.S.A. SPECIFICATIONS A257.2 REINFORCED CLASSES AS SPECIFIED (65-D, 100-D, 140-D,) OR LATEST AMENDMENT UNLESS OTHERWISE SPECIFIED.
 5. ALL SANITARY PVC SEWER PIPES SHALL BE SDR-35 EQUAL CSA SPECIFICATIONS B182.2-M1990 OR LATEST AMENDMENT UNLESS OTHERWISE NOTED.
 6. ALL MANHOLE AND CATCH BASIN EXCAVATIONS TO BE BACKFILLED WITH GRANULAR MATERIAL COMPACTED TO 98% STANDARD PROCTOR DENSITY.
 7. ALL CATCH BASINS AND CATCHBASIN MANHOLES ARE TO INCLUDE SUBDRAIN TREATMENT AS PER DETAIL ON DRAWING D1.
 8. ALL BLIND CONNECTIONS TO MATCH THE INVERT OF THE CATCH BASIN LEAD TO THE SPRINGLINE OF THE STORM PIPE. OTHERWISE INSTALL THE CATCH BASIN LEAD AT A MAXIMUM 2.00% AND DROP INTO PIPE.
 9. UNLESS NOTED OTHERWISE, CATCHBASIN LEADS SHALL BE 250mm @ MINIMUM 1.00% SLOPE.
 10. THE CONTRACTOR IS TO PROVIDE CCTV CAMERA INSPECTIONS OF ALL SANITARY AND STORM SEWERS, INCLUDING PICTORIAL REPORT, TWO (2) CD COPIES AND ONE (1) VIDEO TAPE IN A FORMAT SATISFACTORY TO THE ENGINEER. ALL SEWERS ARE TO BE FLUSHED PRIOR TO CAMERA INSPECTION.
 11. THE CONTRACTOR SHALL CONTACT THE MUNICIPALITY AT LEAST 48 HOURS PRIOR TO CONNECTING TO THE EXISTING SANITARY & STORM MANHOLE.

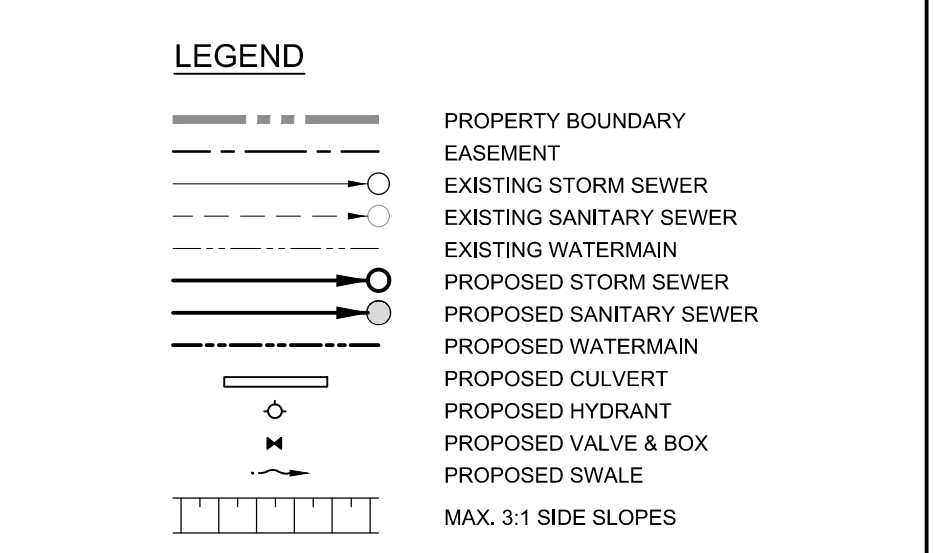
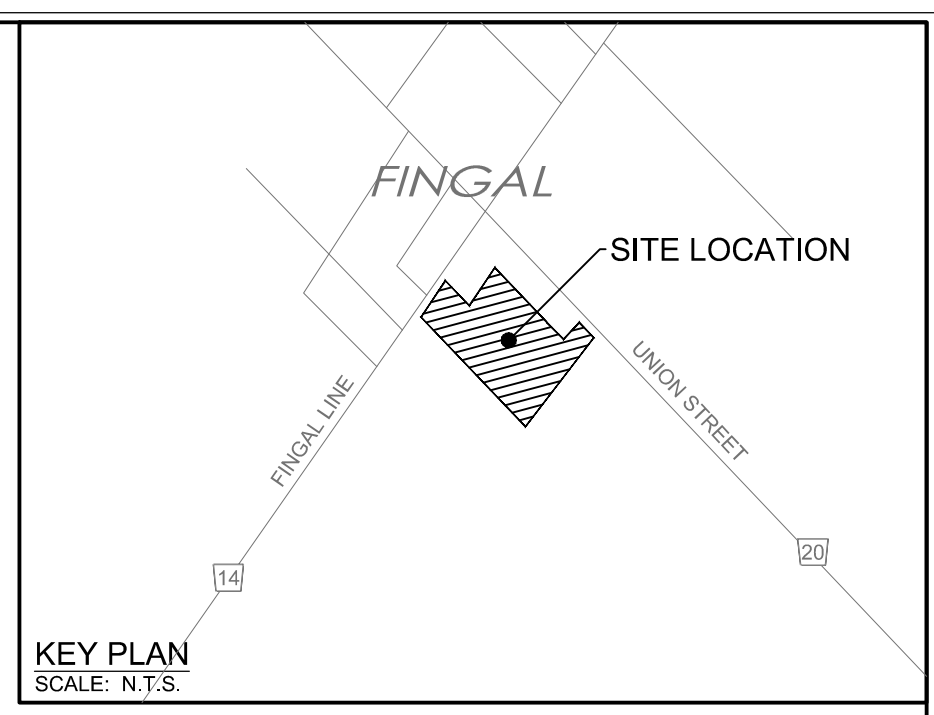

BARIBEAU CONSTRUCTION
EST. 1987
Project Management | Construction Management | Feasibility Studies | Design-Build | Industrial | Commercial | Institutional

Notes:
No additional options or changes proposed.

NOT FOR CONSTRUCTION

No.	Issue / Revision	Date	Auth.
1	ISSUED FOR CLASS D COST ESTIMATE	22/06/08	FG
2	ISSUED FOR 50% DESIGN SUBMISSION	22/07/25	FG
3	ISSUED FOR 90% DESIGN SUBMISSION	22/10/24	FG
4	ISSUED FOR SECOND SUBMISSION	22/11/07	FG
5	ISSUED FOR THIRD SUBMISSION	22/12/14	FG



R.J. Burnside & Associates Limited
35 Perry St.
Woodstock, Ontario, N4S 3C4
telephone (519) 941-5331
fax (519) 271-3790
web www.rjburnside.com

TOWNSHIP OF SOUTHWOLD
35863 FINGAL LINE
FINGAL, ONTARIO
N0L 1K0

Drawing Title:
SOUTHWOLD PUBLIC WORKS BUILDING ADDITION

SERVICING PLAN

Drawn	Checked	Designed	Checked	Date	Drawing No.
BF	FG	BF	FG	22/07/25	
Project No.	Contract No.	Revision No.			
054978	300054978	0			
Scale	0 5.0 10.0 20.0 30.0m				
1:500					

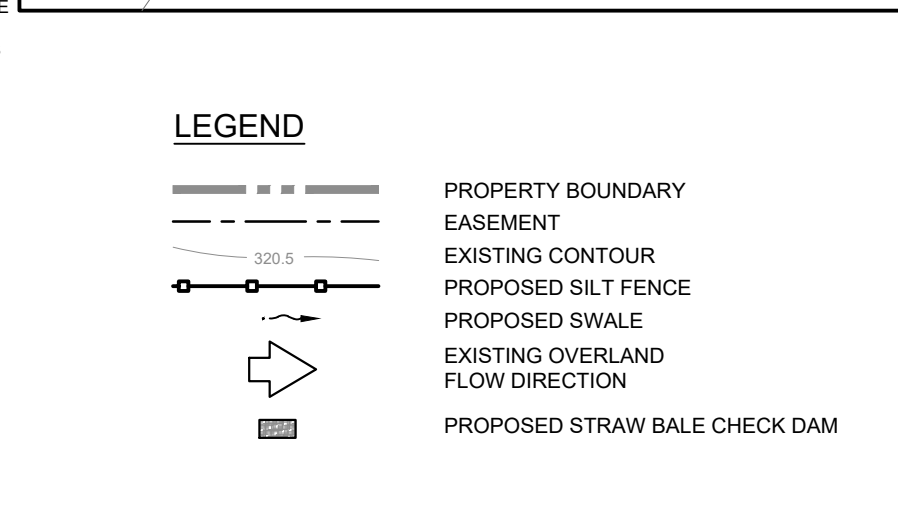
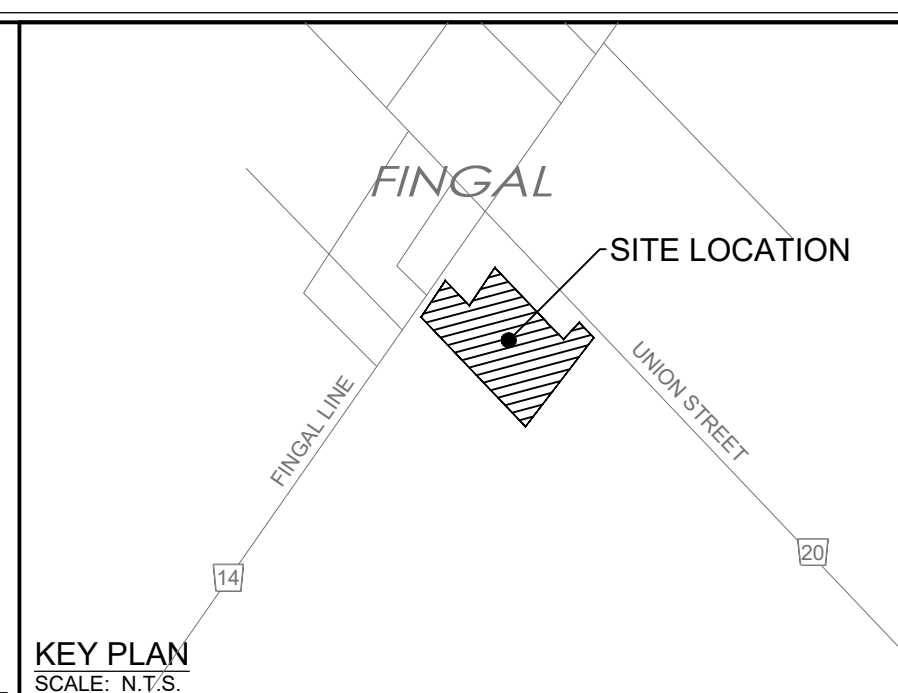

- EROSION AND SEDIMENT CONTROL NOTES**
- UNDER NO CIRCUMSTANCES SHALL THE CONTRACTOR LEAVE A WORK AREA INCOMPLETE AND EXPOSED FOR MORE THAN 10 DAYS WITHOUT PROPER PROTECTION OF THE SLOPE AND EXCAVATED SURFACES AS REQUIRED UNDER THIS CONTRACT, ESPECIALLY WITHIN THE VICINITY OF WATER CROSSINGS/WETLANDS. THIS MAY INCLUDE SEED, SOIL, EROSION CONTROL BLANKET, AND/OR HYDRAULIC MULCH GROUND COVER. IN ADDITION, ALL TEMPORARY AND PERMANENT DITCHES AND EMBANKMENT SLOPES WITHIN 30M OF WATERCOURSES, WETLANDS AND STORM PONDS ARE TO BE STABILIZED WITH TOPSOIL, SEED AND EROSION CONTROL BLANKET IMMEDIATELY FOLLOWING GRADING AND PRIOR TO RECEIVING STORMWATER RUNOFF FLOWS.
 - ALL DISTURBED VEGETATED AREAS SHALL BE STABILIZED AND RESTORED WITH NATIVE/NON-INVASIVE SPECIES UPON COMPLETION OF THE WORK IN ACCORDANCE WITH ESC PLANS.
 - ALL DITCHES SHALL BE STABILIZED WITH TOPSOIL, SEED AND EROSION CONTROL BLANKET IMMEDIATELY FOLLOWING THEIR FINAL GRADING AND PRIOR TO RECEIVING RUNOFF FLOWS.
 - SPILL KITS ARE TO BE KEPT ON-SITE.
 - REGULAR MONITORING SHALL BE COMPLETED AS PER THE EROSION & SEDIMENT CONTROL GUIDELINE FOR URBAN CONSTRUCTION (TRCA, 2019), WHICH INCLUDES THE FOLLOWING MONITORING FREQUENCIES:
 - ON A WEEKLY BASIS
 - AFTER EVERY RAINFALL
 - AFTER SIGNIFICANT SNOWMELT EVENTS, AND
 - DAILY DURING EXTENDED RAIN OR SNOWMELT PERIODS.
 - THE CONTRACTOR MAY CONSIDER ALTERNATIVE SEDIMENT AND EROSION CONTROL MEASURES. SUCH MEASURES MUST BE PRESENTED IN WRITING FOR APPROVAL OF THE ENGINEER AND TOWNSHIP OF SOUTHWOLD.
 - EROSION AND SEDIMENT CONTROL DEVICES TO BE INSTALLED PRIOR TO CLEARING AND/OR GRADING.
 - MUD TRACKING TO BE MONITORED AND MINIMIZED BY THE CONTRACTOR DURING CONSTRUCTION.
 - ALL BOULEVARDS AND DISTURBED AREAS TO BE SODDED OR SEEDED OVER A MINIMUM OF 150mm OF SCREENED TOPSOIL OR APPROVED EQUIVALENT.
 - A COPY OF THE "FOR CONSTRUCTION" PLAN ARE TO BE ON SITE FOR REFERENCE AT ALL TIMES DURING CONSTRUCTION.
 - ALL EXISTING WATERMAIN, STORM AND SANITARY PIPE, ASPHALT, CONCRETE, TOPSOIL AND EARTH EXCAVATION TO BE REMOVED TO A LOCATION AS APPROVED BY THE ENGINEER.
 - EXISTING VEGETATION ON SITE TO BE REMOVED AND DISPOSED OF OFF SITE BEFORE LOT GRADING WORK IF REQUIRED.
 - ALL DOWNSPOUTS, SUMP PUMP AND OTHER DRAINAGE DISCHARGE POINTS SHALL DISCHARGE ON TO A SPLASH PAD OR AS NOTED ON THE DRAWING.

BARIBEAU CONSTRUCTION EST. 1987
 Vision Builders.
 Project Management | Construction Management | Feasibility Studies | Design-Build | Industrial | Commercial | Institutional

Notes:
 No additional options or changes proposed.

NOT FOR CONSTRUCTION

No.	Issue / Revision	Date	Auth.
1	ISSUED FOR CLASS D COST ESTIMATE	22/06/08	FG
2	ISSUED FOR 50% DESIGN SUBMISSION	22/07/25	FG
3	ISSUED FOR 90% DESIGN SUBMISSION	22/10/24	FG
4	ISSUED FOR SECOND SUBMISSION	22/11/07	FG
5	ISSUED FOR THIRD SUBMISSION	22/12/14	FG

NOT FOR CONSTRUCTION

ONTARIO PROVINCIAL STANDARD DRAWING Nov 2015 Rev 2
OPSD 219.180

NOT FOR CONSTRUCTION

LICENSED PROFESSIONAL ENGINEER
 F. T. GOULDING
 100516199
 2022/10/23
 PROVINCE OF ONTARIO

BURNSIDE
 R.J. Burnside & Associates Limited
 35 Perry St.
 Woodstock, Ontario, N4S 3C4
 telephone (519) 344-5331
 fax (519) 271-3790
 web www.rjburnside.com

Client
TOWNSHIP OF SOUTHWOLD
 35663 FINGAL LINE
 FINGAL, ONTARIO
 N0L 1K0

Drawing Title
**SOUTHWOLD PUBLIC WORKS BUILDING
 ADDITION
 EROSION AND SEDIMENT CONTROL PLAN**

Drawn	Checked	Designed	Checked	Date	Drawing No.
BF	FG	BF	FG	22/07/25	

Project No. 054978 Contract No. 300054978 Revision No. 0

Scale 1:500 0 5.0 10.0 20.0 30.0m

ESC1

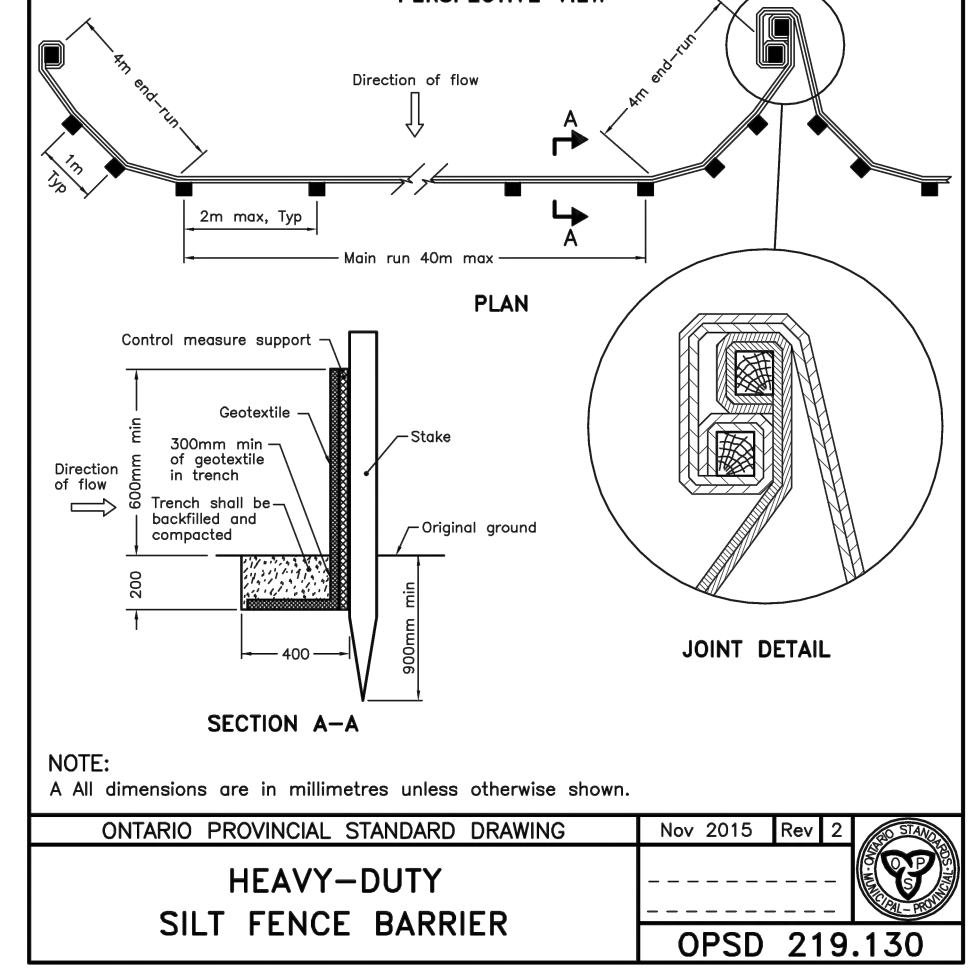
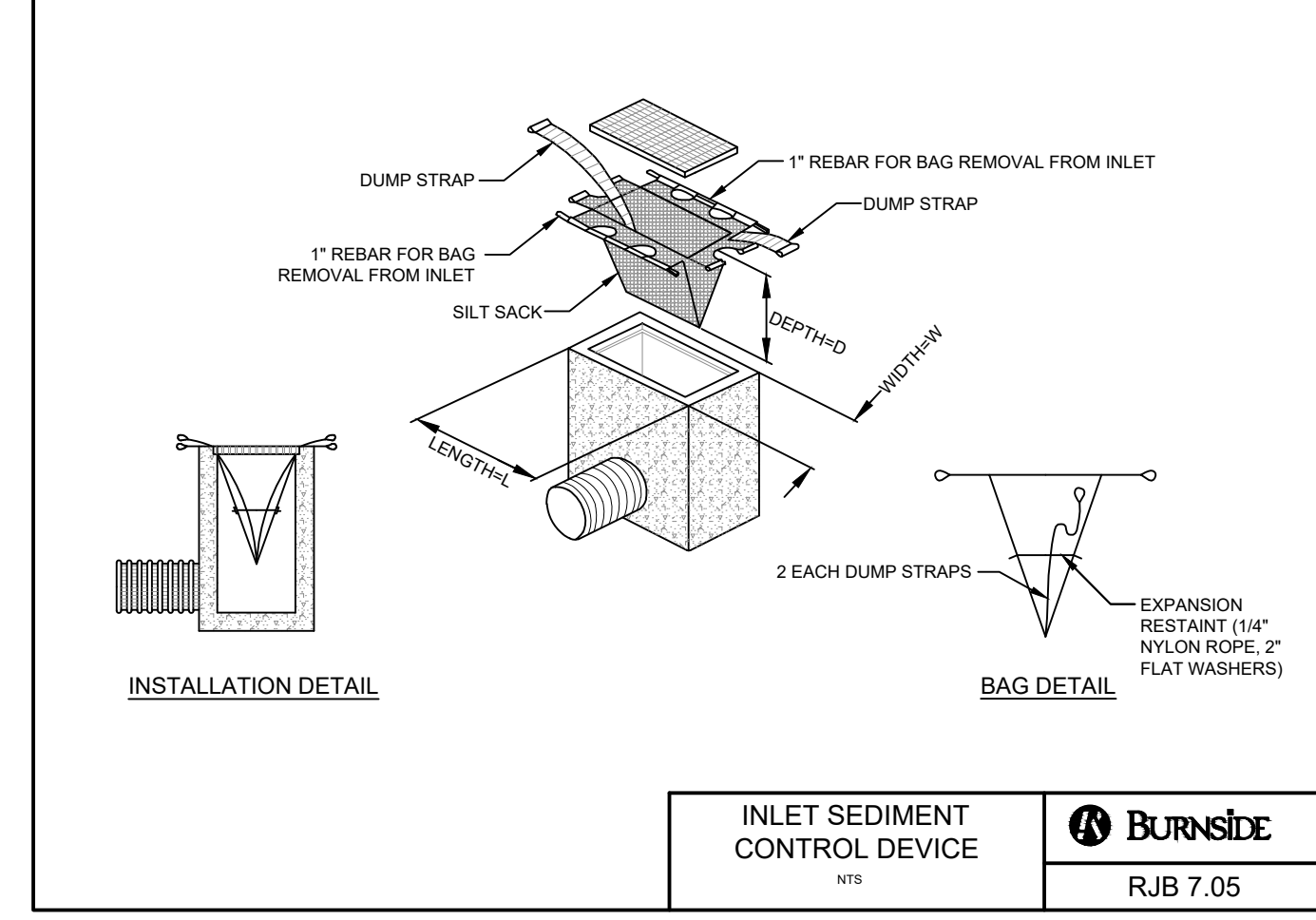
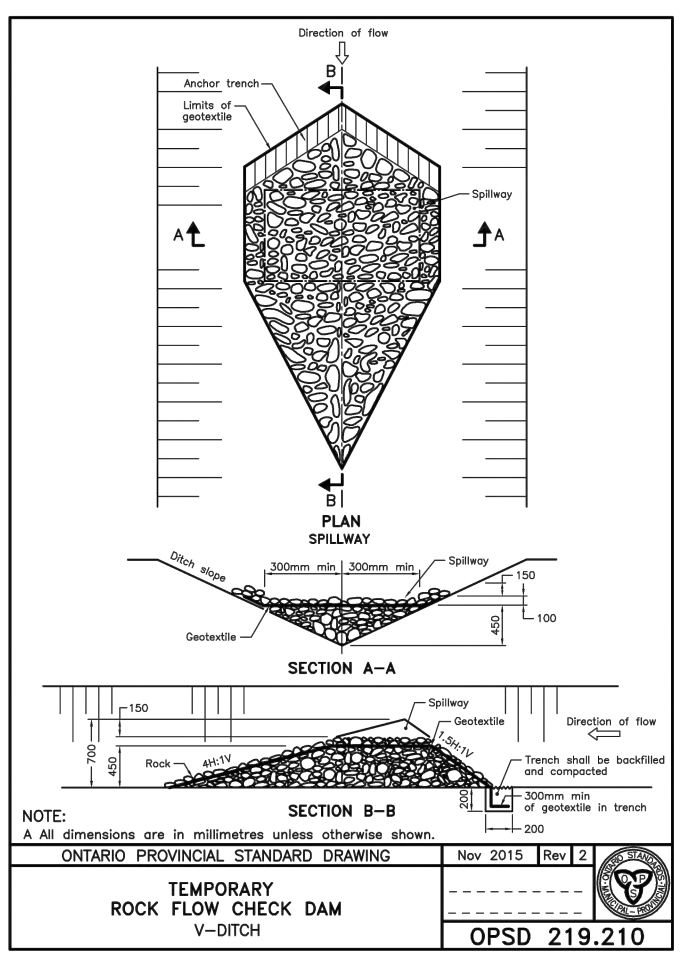
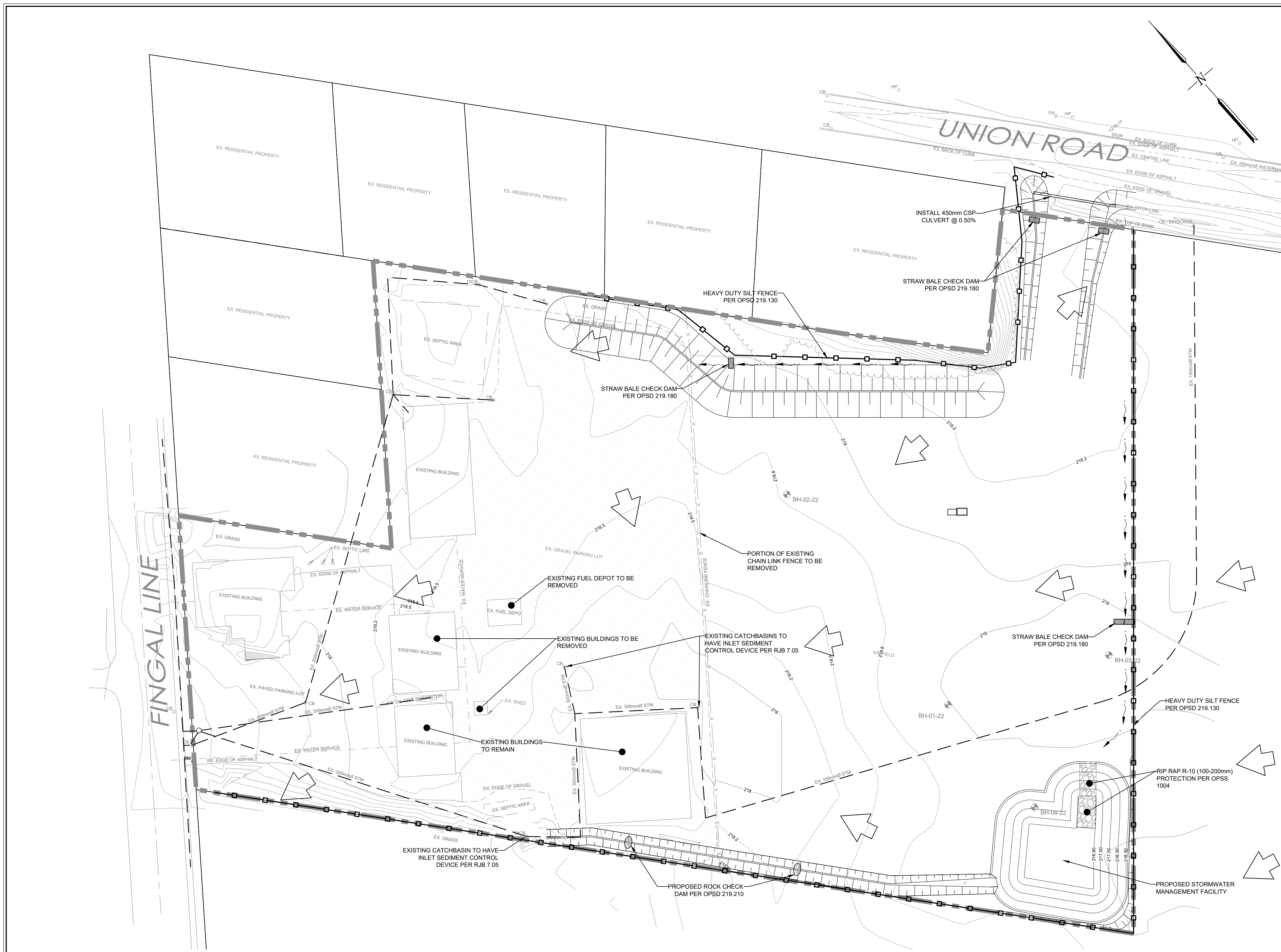

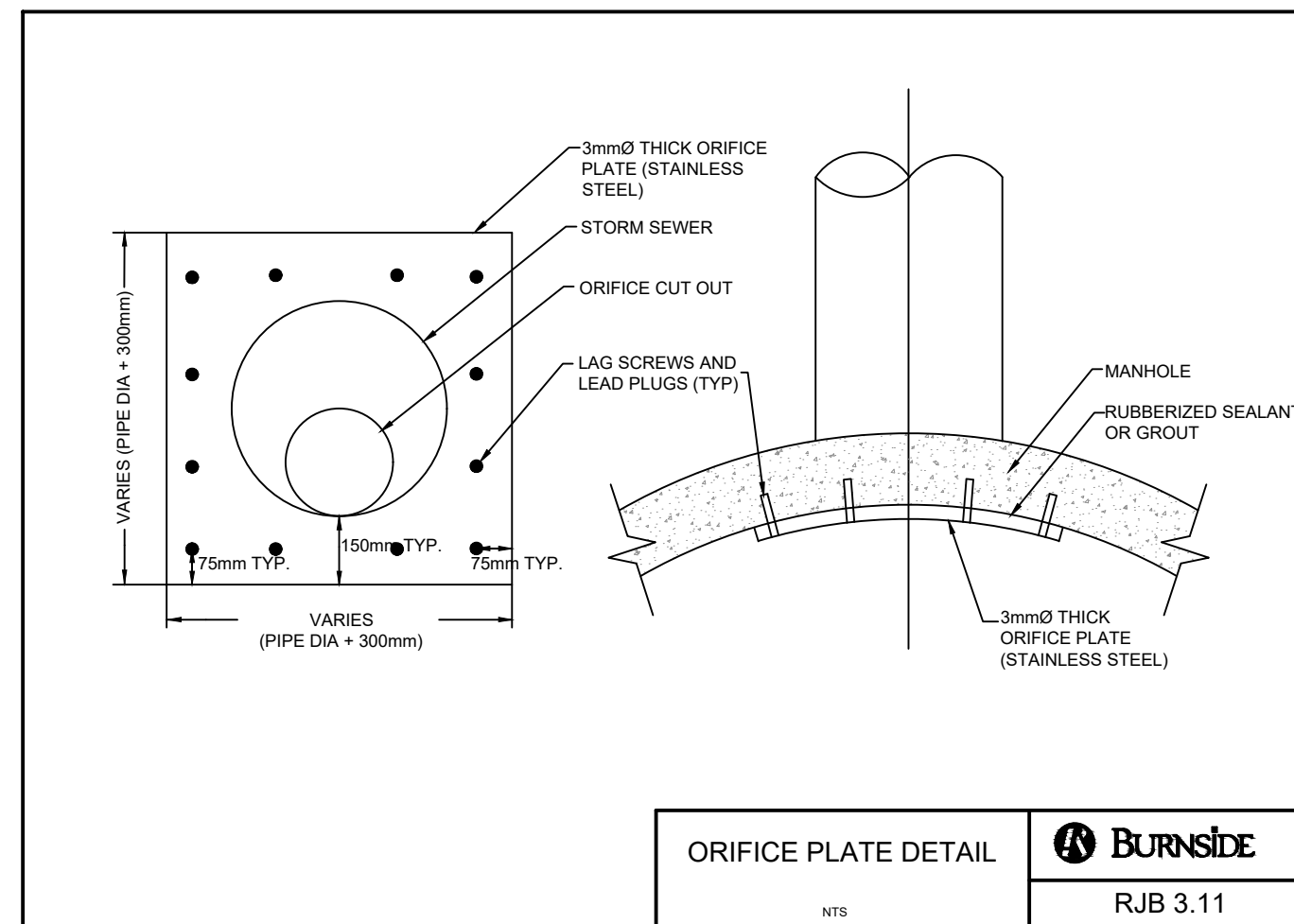

ORIFICE PLATE DETAIL
NTS
RJB 3.11

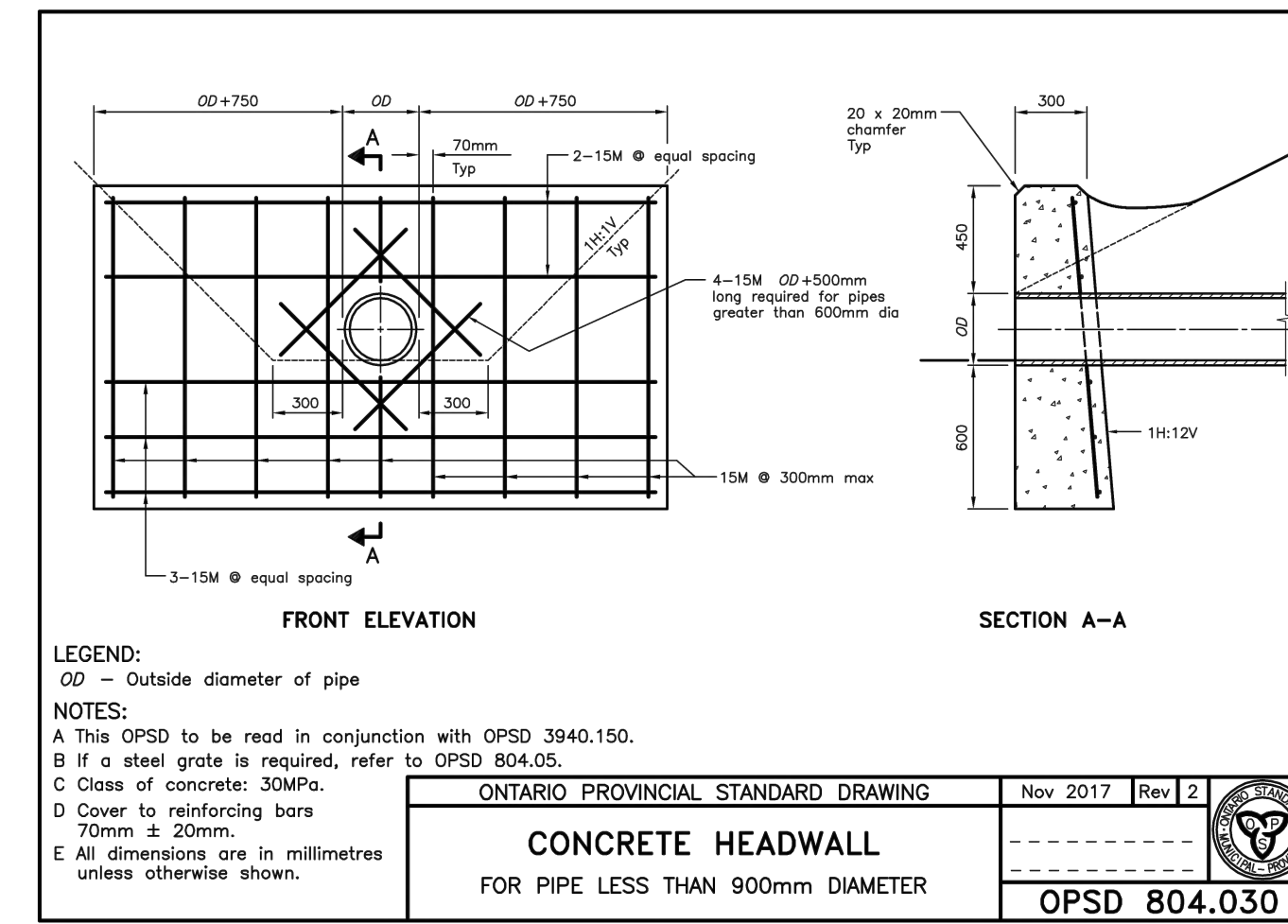

LEGEND:
ØD - Outside diameter of pipe
NOTES:
A This OPSD to be read in conjunction with OPSD 3940.150.
B If a steel grate is required, refer to OPSD 804.05.
C Class of concrete: 30MPa.
D Cover to reinforcing bars: 70mm ± 20mm.
E All dimensions are in millimetres unless otherwise shown.

ONTARIO PROVINCIAL STANDARD DRAWING
CONCRETE HEADWALL
FOR PIPE LESS THAN 900mm DIAMETER
Nov 2017 Rev 2
OPSD 804.030

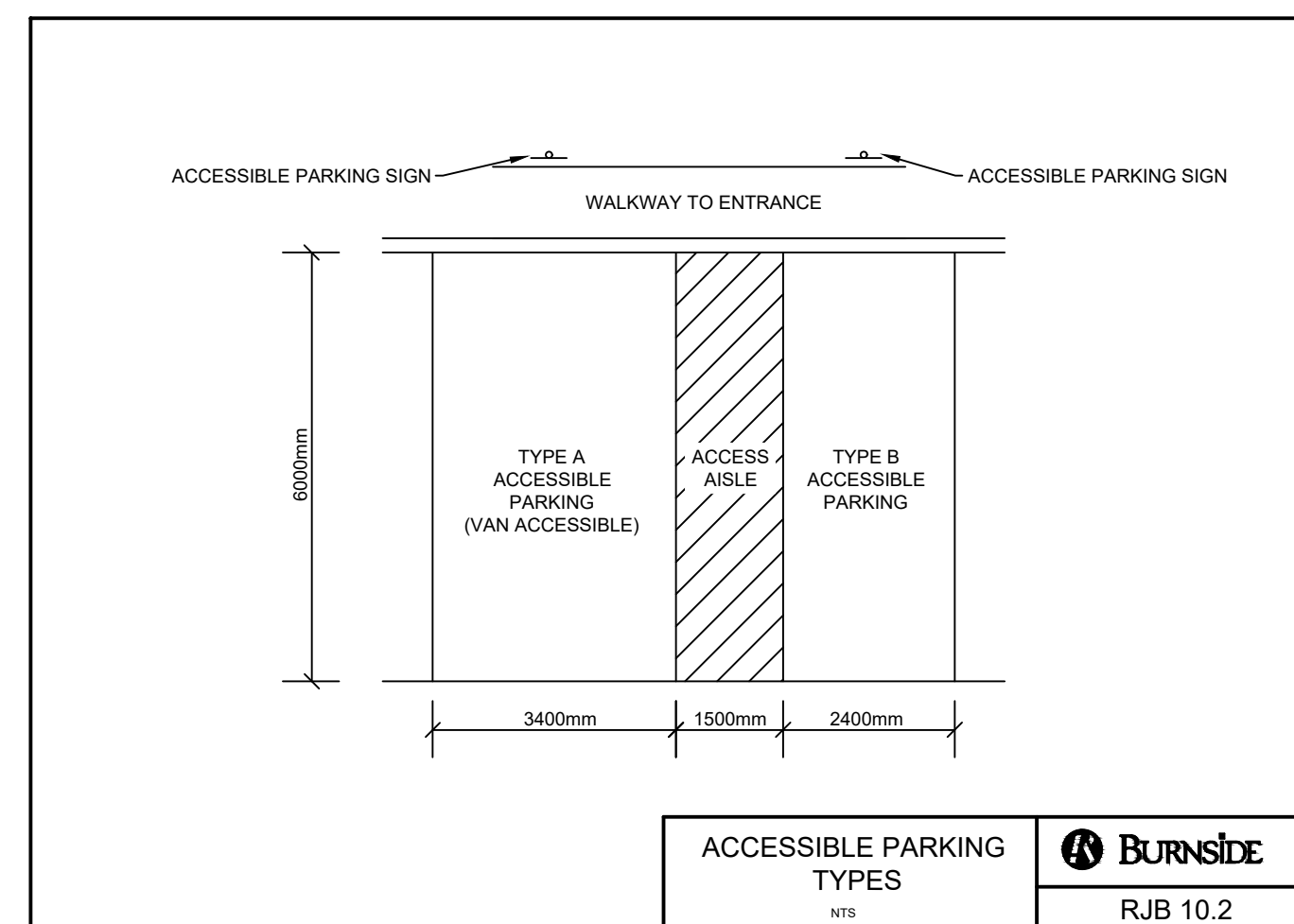

ACCESSIBLE PARKING TYPES
NTS
RJB 10.2

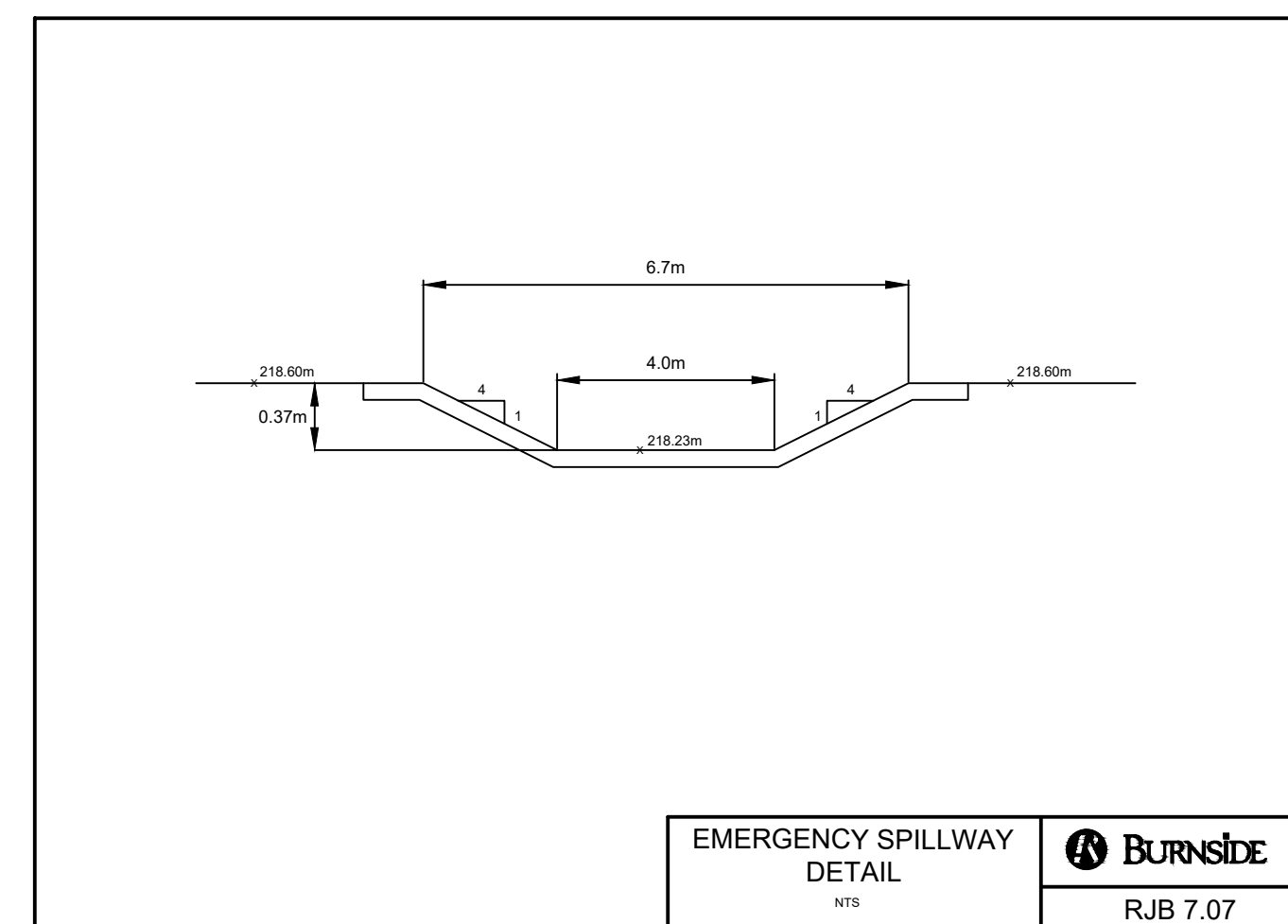

EMERGENCY SPILLWAY DETAIL
NTS
RJB 7.07



Notes:
No additional options or changes proposed.

- Notes
- This drawing is the exclusive property of R. J. Burnside & Associates Limited. The reproduction of any part without prior written consent of this office is strictly prohibited.
 - The contractor shall verify all dimensions, levels, and datums on site and report any discrepancies or omissions to this office prior to construction.
 - This drawing is to be read and understood in conjunction with all other plans and documents applicable to this project.

NOT FOR CONSTRUCTION

No.	Issue / Revision	Date	Auth.
1	ISSUED FOR CLASS D COST ESTIMATE	22/06/08	FG
2	ISSUED FOR 50% DESIGN SUBMISSION	22/07/25	FG
3	ISSUED FOR 90% DESIGN SUBMISSION	22/10/24	FG
4	ISSUED FOR SECOND SUBMISSION	22/11/07	FG
5	ISSUED FOR THIRD SUBMISSION	22/12/14	FG



BURNSIDE
R. J. Burnside & Associates Limited
35 Perry St.
Woodstock, Ontario, N4S 3C4
telephone (519) 941-5331
fax (519) 271-3790
web www.rjburnside.com

Client
TOWNSHIP OF SOUTHWOLD
35663 FINGAL LINE
FINGAL, ONTARIO
N0L 1K0

Drawing Title
**SOUTHWOLD PUBLIC WORKS BUILDING
ADDITION
DETAILS**

Drawn	Checked	Designed	Checked	Date	Drawing No.
BF	FG	BF	FG	22/07/25	
Project No. 054978	Contract No. 30054978	Revision No. 0			D1

Scale
AS NOTED

File: \\burnside\shared\work\Areas\24188\Southwold Public Works BLDG Addition\03_Production\Drawings\01_Details.dwg Date Plotted: December 08, 2022 - 1:07 PM

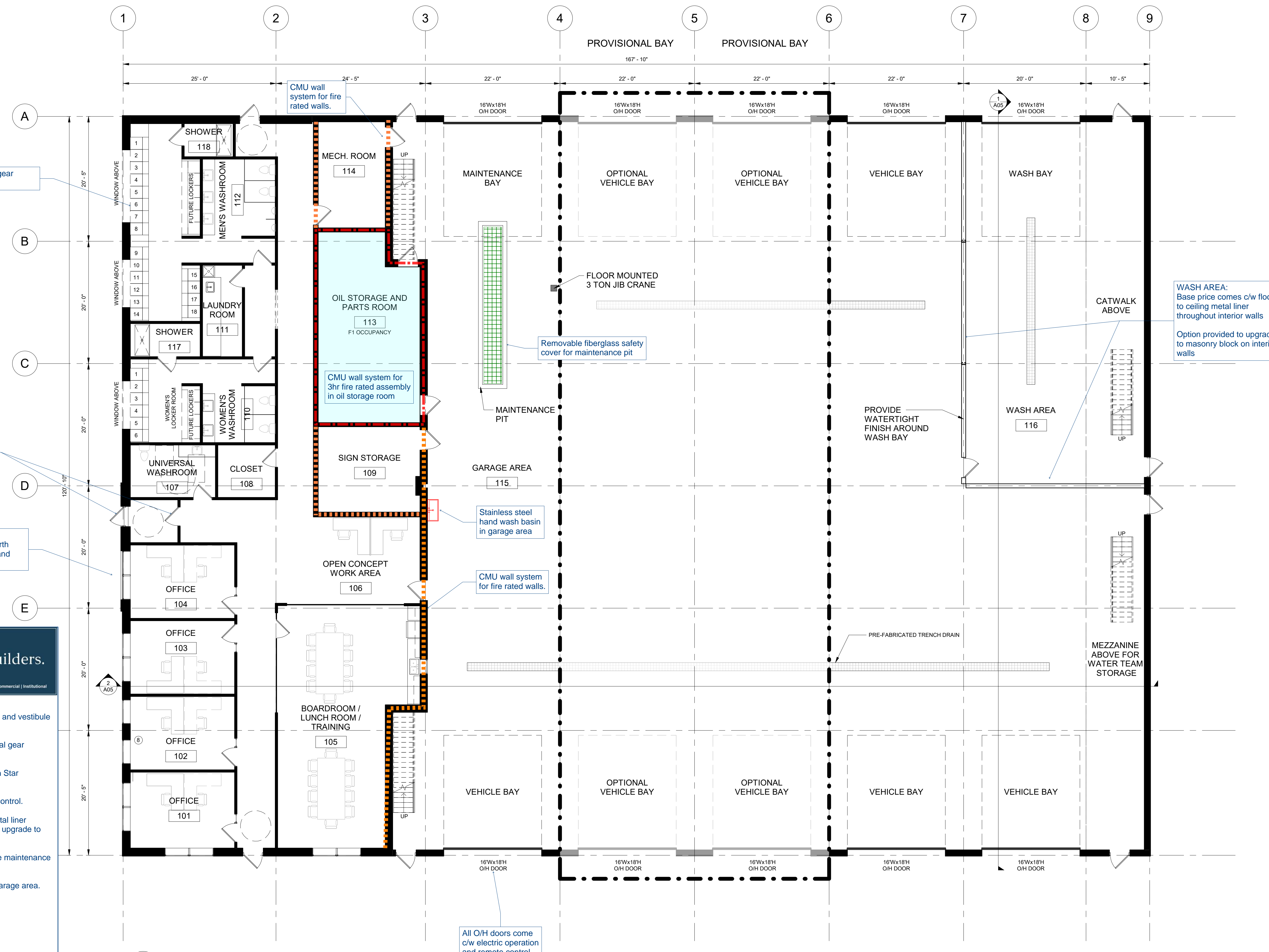

24" wide metal gear locker

Aluminum Entrance Door with push button operators. Fully accessible

Vinyl Windows Supplied by North Star Windows and Doors

WASH AREA:
Base price comes c/w floor to ceiling metal liner throughout interior walls
Option provided to upgrade to masonry block on interior walls

All O/H doors come c/w electric operation and remote control.



- Notes:**
- We included a fully accessible aluminum front entrance and vestibule doors.
 - We included the supply and installation of 24x (24" metal gear lockers).
 - All windows to be vinyl windows manufactured by North Star Windows and Doors.
 - All O/H doors come c/w electric operation and remote control.
 - WASH AREA: Base price comes c/w floor to ceiling metal liner throughout interior walls. As option has been provided to upgrade to CMU system for interior partition walls.
 - We included a removable fiberglass safety cover for the maintenance pit.
 - We included a stainless steel hand wash basin in the garage area.

- Exclusions:**
- Administrative furniture

1 MAIN FLOOR PLAN DESIGN BUILD
A01 Scale: 1/8" = 1'-0"

NOT FOR CONSTRUCTION

No.	Issue / Revision	Date	Auth.
1	ISSUED FOR DESIGN BUILD	24/02/20	

		R.J. Burnside & Associates Limited 292 Speedvale Ave. W., Unit 20 Guelph, Ontario, N1H 1C4 telephone (519) 823-4995 fax (519) 836-5477 web www.rjburnside.com		Drawing Title PUBLIC WORKS BUILDING MAIN FLOOR																							
TOWNSHIP OF SOUTHWOLD 35863 FINGAL LINE, FINGAL, ONTARIO N0L 1K0		Client: TOWNSHIP OF SOUTHWOLD 35863 FINGAL LINE, FINGAL, ONTARIO N0L 1K0		<table border="1"> <tr> <td>Drawn</td> <td>Checked</td> <td>Designed</td> <td>Checked</td> <td>Date</td> <td>Drawing No.</td> </tr> <tr> <td>T.T.</td> <td>M.K.</td> <td>M.K.</td> <td>M.K.</td> <td>24/02/20</td> <td rowspan="3">A01</td> </tr> <tr> <td>Project No.</td> <td>Contract No.</td> <td>Revision No.</td> <td></td> <td></td> </tr> <tr> <td>300054978</td> <td></td> <td>1</td> <td></td> <td></td> </tr> </table>		Drawn	Checked	Designed	Checked	Date	Drawing No.	T.T.	M.K.	M.K.	M.K.	24/02/20	A01	Project No.	Contract No.	Revision No.			300054978		1		
Drawn	Checked	Designed	Checked	Date	Drawing No.																						
T.T.	M.K.	M.K.	M.K.	24/02/20	A01																						
Project No.	Contract No.	Revision No.																									
300054978		1																									
Scale: AS NOTED																											

C:\Users\jburnside\Documents\Drawings\55893_P\Drawings\Public Works Building\OPTIONAL_A_2021_1\rev000000070501.rvt

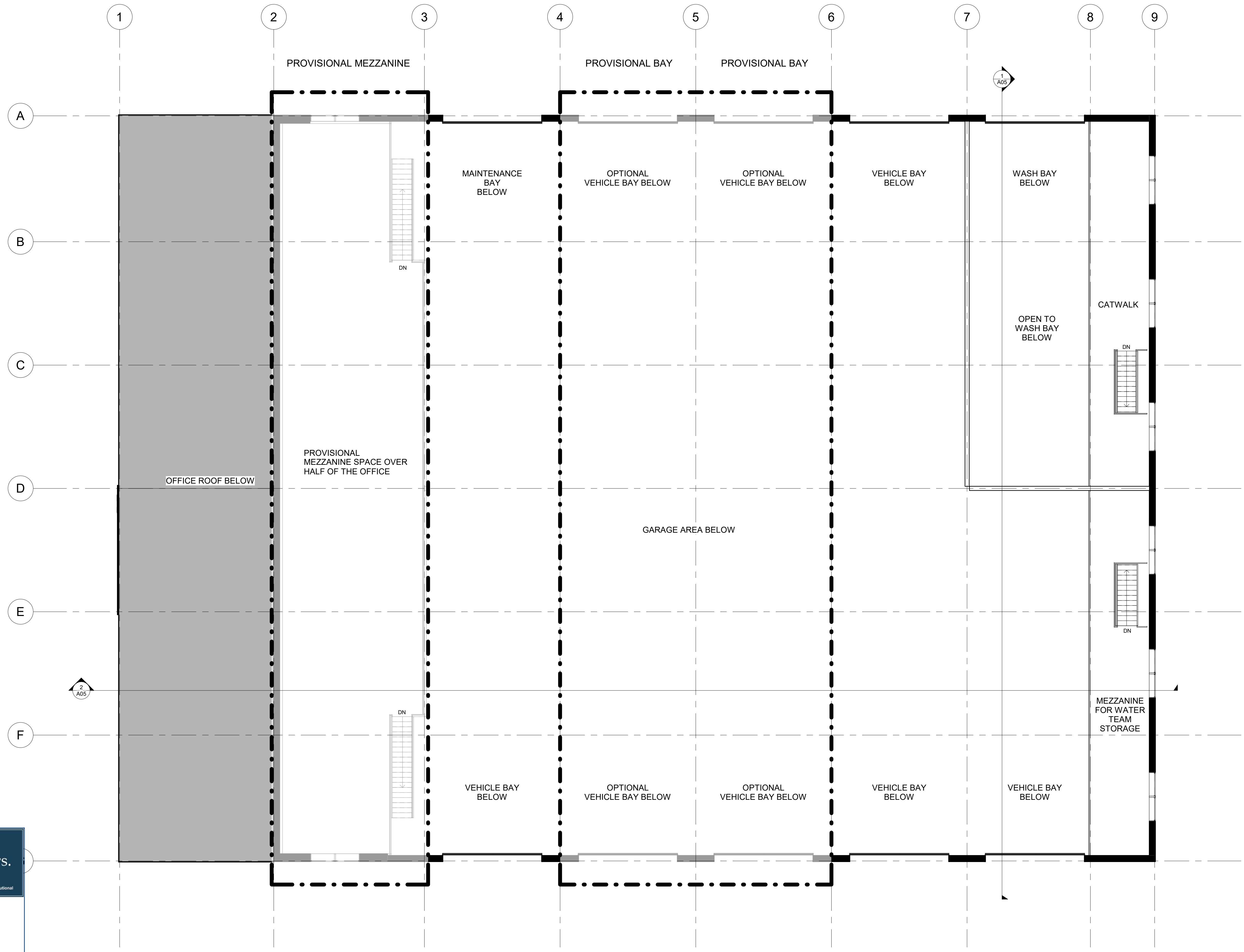

1 MEZZANINE PLAN DESIGN BUILD
A02 Scale: 1/8" = 1'-0"



Notes:
No additional options or changes proposed.

Notes:
1. This drawing is the exclusive property of R.J. Burnside & Associates Limited. The reproduction of any part without prior written consent of this office is strictly prohibited.
2. The contractor shall verify all dimensions, levels, and datums on site and report any discrepancies or omissions to this office prior to construction.
3. This drawing is to be read and understood in conjunction with all other plans and documents applicable to this project.

No.	Issue / Revision	Date	Auth.
1	ISSUED FOR DESIGN BUILD	24/02/20	

NOT FOR CONSTRUCTION

BURNSIDE
R.J. Burnside & Associates Limited
292 Speedvale Ave. W., Unit 20
Guelph, Ontario, N1H 1C4
telephone (519) 823-4995
fax (519) 836-5477
web www.rjburnside.com

Client: **TOWNSHIP OF SOUTHWOLD**
35863 FINGAL LINE,
FINGAL, ONTARIO
N0L 1K0

Drawing Title					Drawing No.
PUBLIC WORKS BUILDING MEZZANINES					
Drawn	Checked	Designed	Checked	Date	Revision No.
T.T.	M.K.	M.K.	M.K.	24/02/20	
Project No: 300054978					A02
Scale: AS NOTED					

C:\Users\jburnside\Documents\Drawings\2020\Public Works Building\OPTIONAL_A_2021_1\mezzanines\pvt.dwg

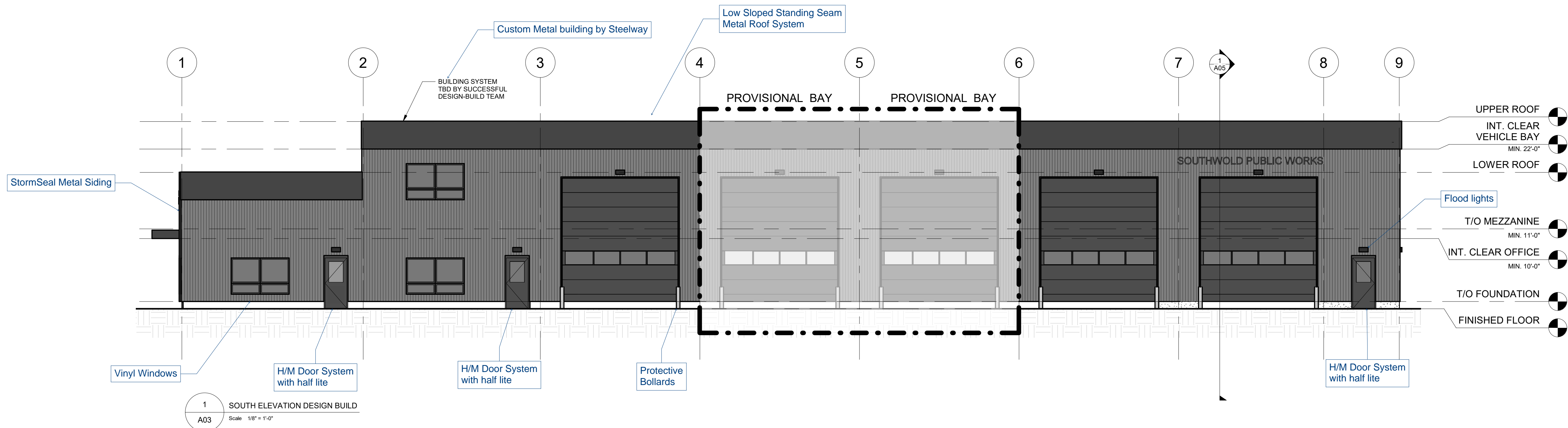

1 SOUTH ELEVATION DESIGN BUILD
A03 Scale: 1/8" = 1'-0"

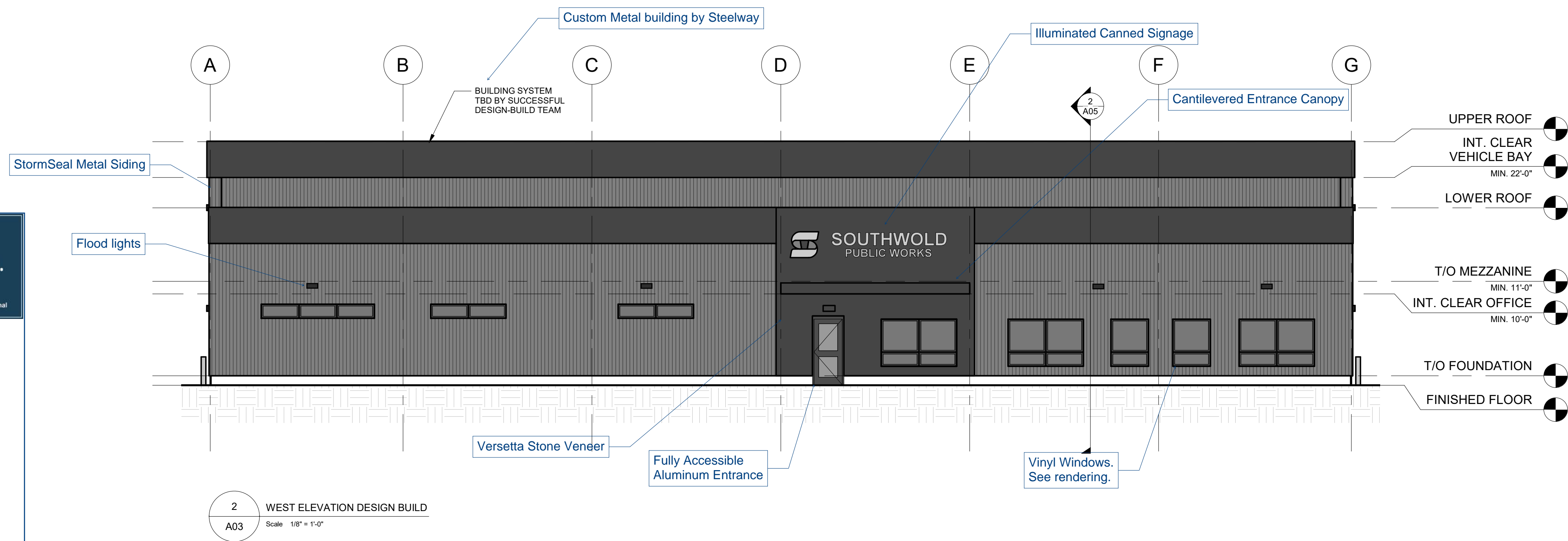

2 WEST ELEVATION DESIGN BUILD
A03 Scale: 1/8" = 1'-0"



Project Management | Construction Management | Feasibility Studies | Design-Build | Industrial | Commercial | Institutional

Notes:

- We included a fully accessible aluminum front entrance and vestibule doors.
- All windows to be vinyl windows manufactured by North Star Windows and Doors.
- All O/H doors come c/w electric operation and remote control.
- Refer to renderings and Steelway drawings for structure details
- Building will be clad with StormSeal Metal Siding
- We are proposing a low sloped Standing Seam Metal Roof system supplied by Steelway.
- Versetta Stone Veneer will outline the front entrance. See rendering.

Exclusions:

- Notes:
1. This drawing is the exclusive property of R.J. Burnside & Associates Limited. The reproduction of any part without prior written consent of this office is strictly prohibited.
 2. The contractor shall verify all dimensions, levels, and datums on site and report any discrepancies or omissions to this office prior to construction.
 3. This drawing is to be read and understood in conjunction with all other plans and documents applicable to this project.

No.	Issue / Revision	Date	Auth.
1	ISSUED FOR DESIGN BUILD	24/02/20	

NOT FOR CONSTRUCTION



Client:
TOWNSHIP OF SOUTHWOLD
35863 FINGAL LINE,
FINGAL, ONTARIO
N0L 1K0

R.J. Burnside & Associates Limited
292 Speedvale Ave. W., Unit 20
Guelph, Ontario N1H 1C4
telephone (519) 823-4995
fax (519) 836-5477
web www.rjburnside.com

Drawing Title
PUBLIC WORKS BUILDING

ELEVATIONS

Drawn	Checked	Designed	Checked	Date	Drawing No.
T.T.	M.K.	M.K.	M.K.	24/02/20	A03
Project No. 300054978	Contract No.	Revision No. 1	Scale AS NOTED		

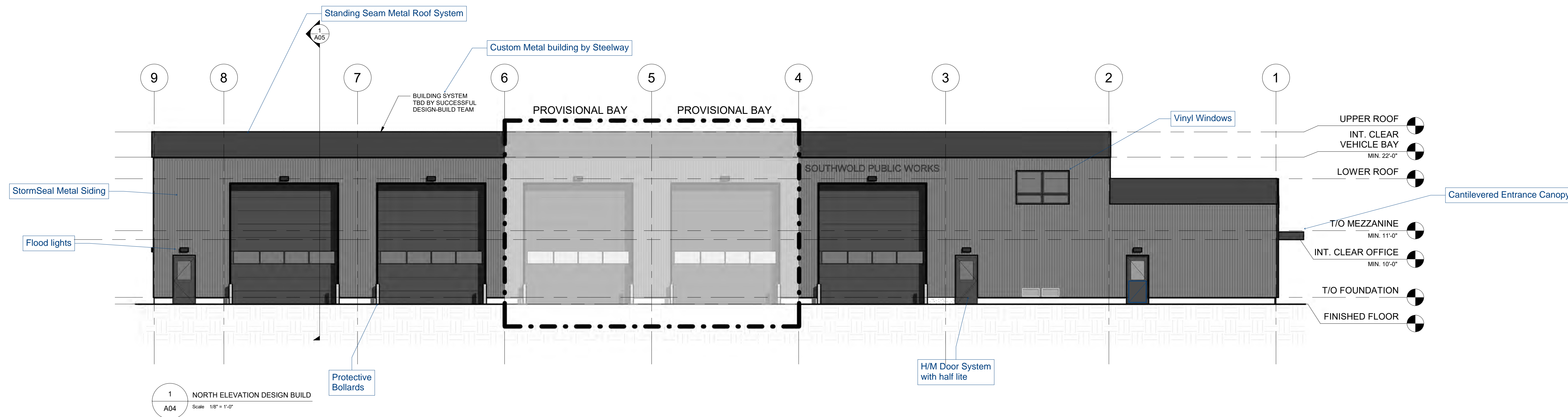

1 NORTH ELEVATION DESIGN BUILD
A04 Scale 1/8" = 1'-0"

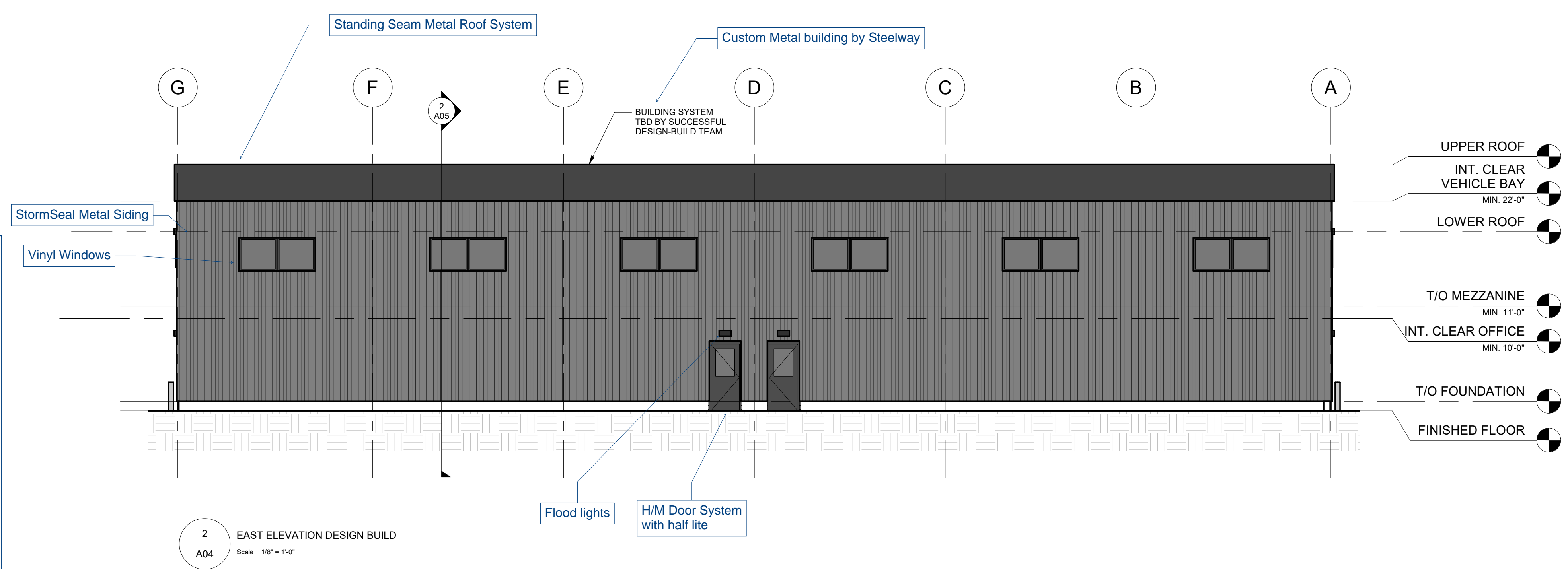

2 EAST ELEVATION DESIGN BUILD
A04 Scale 1/8" = 1'-0"



- Notes:**
- All windows to be vinyl windows manufactured by North Star Windows and Doors.
 - All O/H doors come c/w electric operation and remote control.
 - Refer to renderings and Steelway drawings for structure details
 - Building will be clad with StormSeal Metal Siding

Exclusions:

Notes:
1. This drawing is the exclusive property of R.J. Burnside & Associates Limited. The reproduction of any part without prior written consent of this office is strictly prohibited.
2. The contractor shall verify all dimensions, levels, and datums on site and report any discrepancies or omissions to this office prior to construction.
3. This drawing is to be read and understood in conjunction with all other plans and documents applicable to this project.

No.	Issue / Revision	Date	Auth.
1	ISSUED FOR DESIGN BUILD	24/02/20	

NOT FOR CONSTRUCTION

BURNSIDE
R.J. Burnside & Associates Limited
292 Speedvale Ave. W., Unit 20
Guelph, Ontario N1H 1C4
Telephone (519) 823-4995
Fax (519) 836-5477
Web www.rjburnside.com

Client: **TOWNSHIP OF SOUTHWOLD**
35863 FINGAL LINE,
FINGAL, ONTARIO
N0L 1K0

Drawing Title					Drawing No.
PUBLIC WORKS BUILDING					
ELEVATIONS					
Drawn	Checked	Designed	Checked	Date	Revision No.
T.T.	M.K.	M.K.	M.K.	24/02/20	
Project No. 300054978					A04
Scale AS NOTED					

C:\Users\jburnside\Documents\Drawings\2020\Public Works Building\DWG\A04.dwg

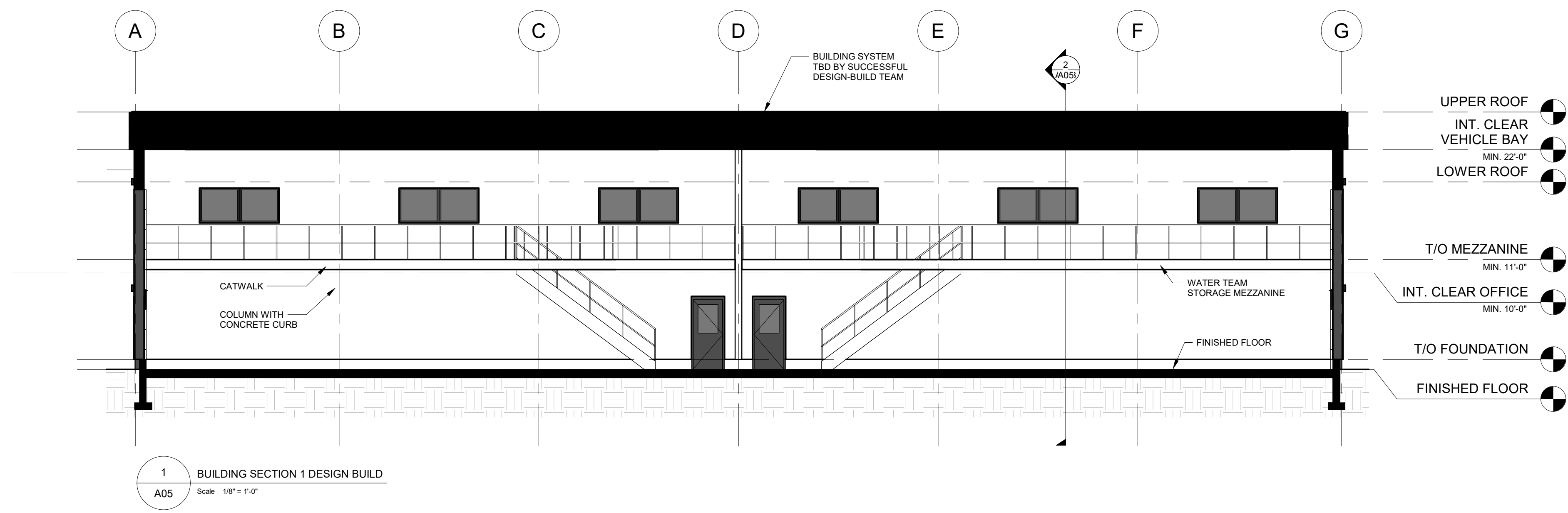

1 BUILDING SECTION 1 DESIGN BUILD
A05 Scale: 1/8" = 1'-0"

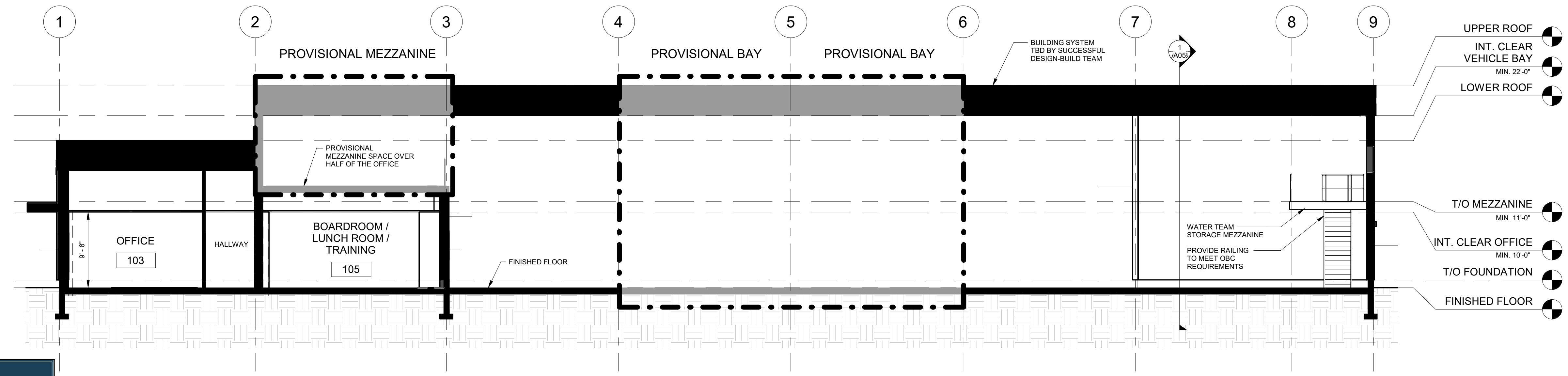

2 BUILDING SECTION 2 DESIGN BUILD
A05 Scale: 1/8" = 1'-0"

BARIBEAU CONSTRUCTION
EST. 1987
Vision Builders.
Project Management | Construction Management | Feasibility Studies | Design-Build | Industrial | Commercial | Institutional

Notes:
- Mezzanine and provisional bays provided as an option per the RFP.

- Notes:
- This drawing is the exclusive property of R.J. Burnside & Associates Limited. The reproduction of any part without prior written consent of this office is strictly prohibited.
 - The contractor shall verify all dimensions, levels, and datums on site and report any discrepancies or omissions to this office prior to construction.
 - This drawing is to be read and understood in conjunction with all other plans and documents applicable to this project.

No.	Issue / Revision	Date	Auth.
1	ISSUED FOR DESIGN BUILD	24/02/20	

NOT FOR CONSTRUCTION

BURNSIDE
R.J. Burnside & Associates Limited
292 Speedvale Ave. W., Unit 20
Guelph, Ontario N1H 1C4
telephone (519) 823-4995
fax (519) 836-5477
web www.rjburnside.com

Client:
TOWNSHIP OF SOUTHWOLD
35863 FINGAL LINE,
FINGAL, ONTARIO
N0L 1K0

Drawing Title					
PUBLIC WORKS BUILDING					
BUILDING SECTIONS					
Drawn	Checked	Designed	Checked	Date	Drawing No.
T.T.	M.K.	M.K.	M.K.	24/02/20	A05
Project No.	Contract No.	Revision No.			
300054978		1			
Scale	AS NOTED				

C:\Users\jburnside\Documents\Drawings\2021\1\rev\comp\p070501.rvt

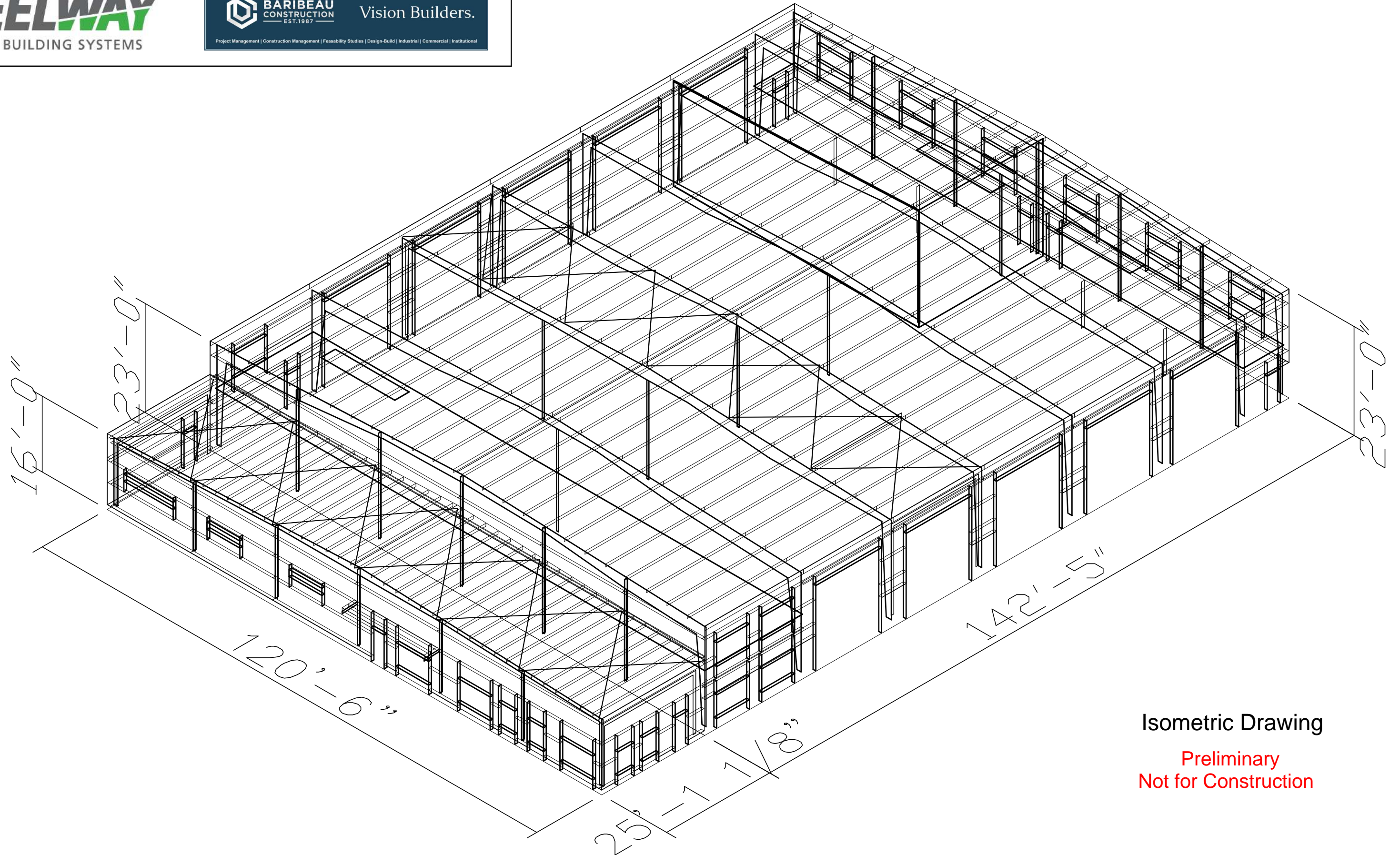

Isometric Drawing

Preliminary
Not for Construction

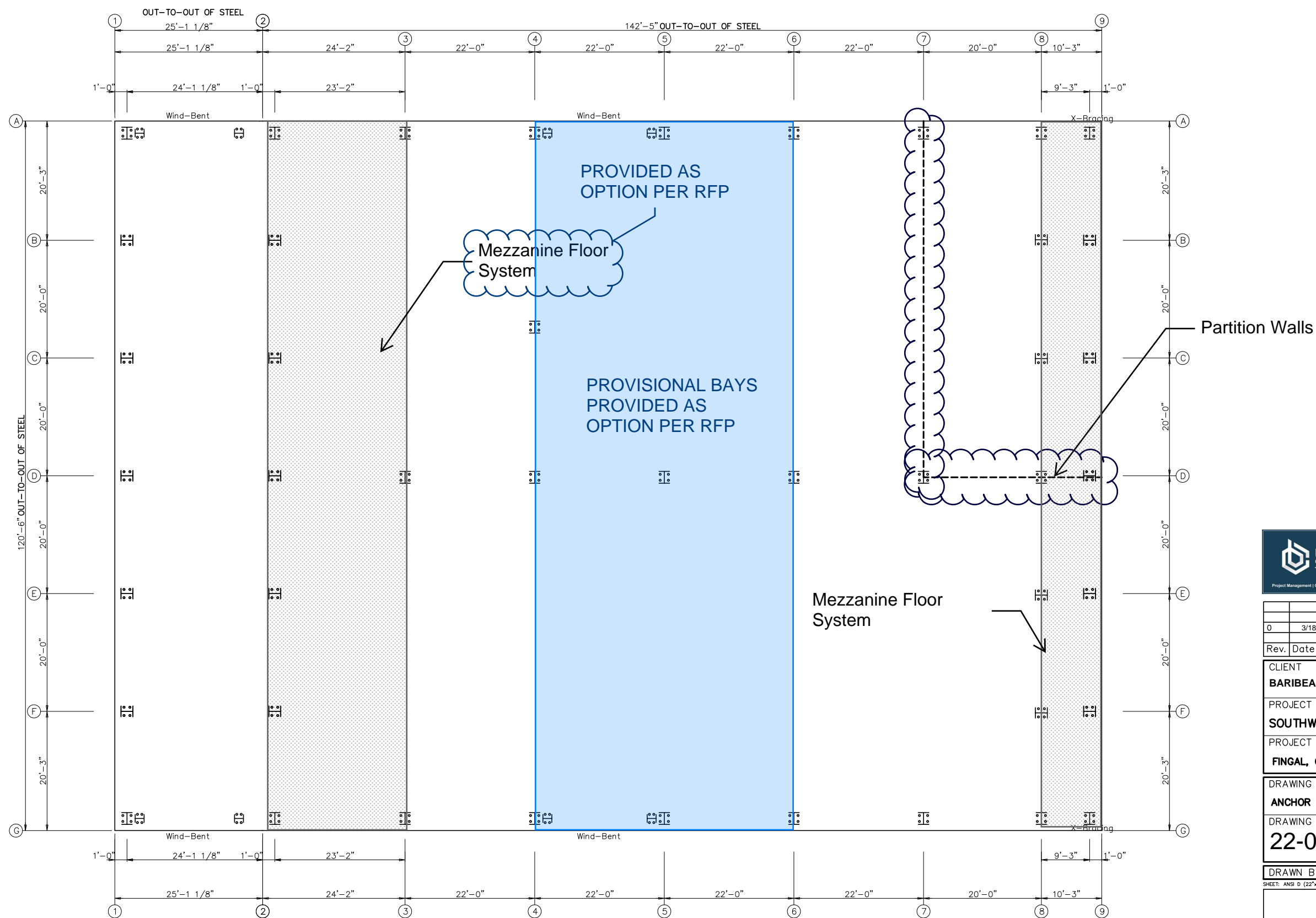

ANCHOR BOLT PLAN
 NOTE: Underside of All Base Plates @ 100'-0" (U.N.)
 - - - - - Partition Wall (See KeyDwg)

- NOTES:
- 1: ALL ANCHOR BOLT DIMENSIONS ARE CENTER TO CENTER OF BOLTS IN INCHES U.N. X'-XX".
 - 2: ANCHOR BOLT PLACEMENT MUST MEET CAN/CSA S16.1 TOLERANCES.
 - 3: REFER TO CHART ON FOLLOWING PAGE TO DETERMINE REQUIRED ANCHOR BOLT PROJECTION FROM U/S BASE PLATE.

BARIBEAU CONSTRUCTION Vision Builders.
 EST. 1987
 Project Management | Construction Management | Feasibility Studies | Design-Build | Industrial | Commercial | Institutional

Rev.	Date	By	Description
0	3/18/2024	VP	ISSUED FOR INFORMATION

CLIENT
BARIBEAU CONSTRUCTION

PROJECT
SOUTHWOLD PUBLIC WORKS BLDG.

PROJECT LOCATION
FINGAL, ONTARIO

DRAWING NAME
ANCHOR BOLT PLAN

DRAWING No.
22-0522-0200

DRAWN BY **X** CHECKED BY **X**
 SHEET: ANSI D (22"x34") ENGINEER'S SEAL APPLIES ONLY TO STEELWAY PRODUCTS

Preliminary
 Not for Construction

STEELWAY BUILDING SYSTEMS

7825 Springwater Road
 Aylmer, Ontario N5H 2R4
 519.765.2244
 steelway.com

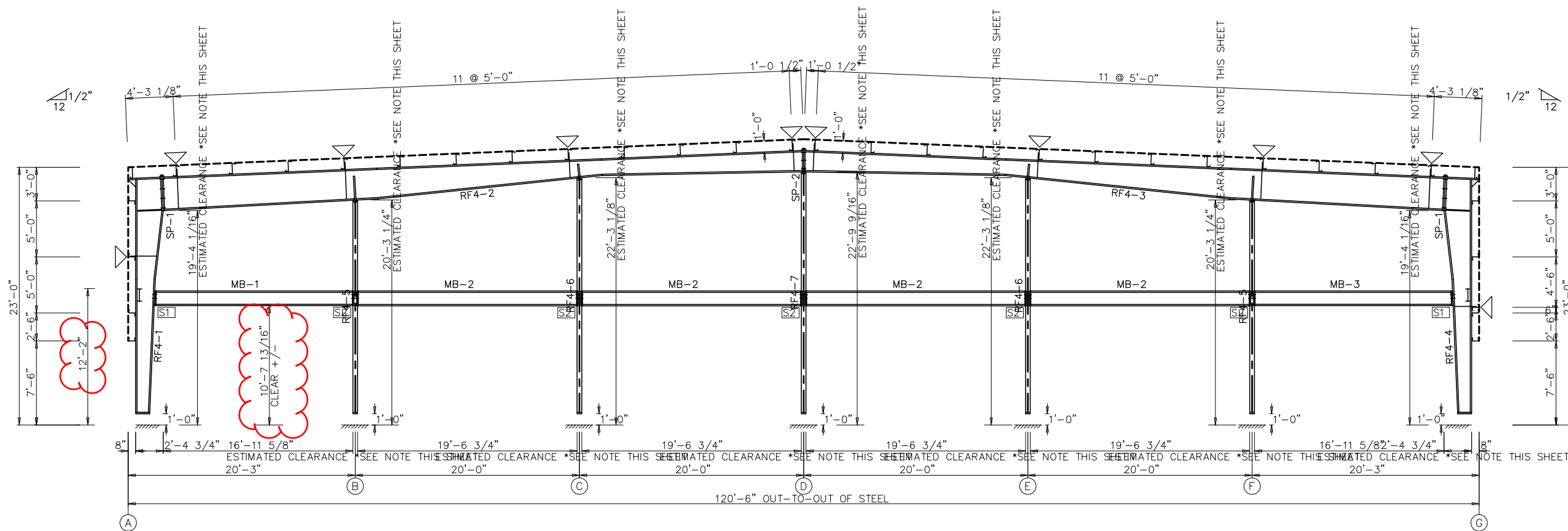

RIGID FRAME ELEVATION: FRAME LINE 2



Rev.	Date	By	Description
0	3/18/2024	VP	ISSUED FOR INFORMATION

CLIENT	BARIBEAU CONSTRUCTION
PROJECT	SOUTHWOLD PUBLIC WORKS BLDG.
PROJECT LOCATION	FINGAL, ONTARIO

DRAWING NAME	RIGID FRAME ELEVATION
DRAWING No.	22-0522-0200

DRAWN BY **X** CHECKED BY **X**
SHEET: ANSI D (22"x34") ENGINEER'S SEAL APPLIES ONLY TO STEELWAY PRODUCTS

Preliminary
Not for Construction





EXCLUSIONS

27

1 SNOW REMOVAL
We assume the municipality can provide snow removal for this site and save the cost of an outside contractor

2 TEMP HYDRO
We assume we can hook up and utilize the existing power on site

3 TEMP WATER CONNECTION
We assume we can hook up and utilize the existing water on site

4 REMOVAL OF EX. FUEL DEPOT
Per addendum #2, we have not included for the removal of the depot identified on SIT1

5 SUPPLY AND INSTALLATION OF USED OIL TANK
Assumed to be provided by municipality

6 SITE PLAN APPROVAL
Per addendum #1 we understand that R.J. Burnside & Associates Limited will be taking responsibility Site Plan Approval

7 PROCESS EQUIPMENT
process equipment is assumed to be provided by the owner

8 ADMINISTRATIVE FURNITURE
We assume the owner will purchase their own furniture for the offices, lunch room, and work areas

9 OPTIONS AND PROVISIONS ITEMS
Options and provision items are not included in the base bid

10 BUILDING PERMIT & DEVELOPMENT CHARGES
We are not including any costs for the building permit fees or development charges. It is assumed those fees will be waived by the municipality.

11 SITE LIGHTING
Per RFP, only site lighting mounted to the building has been included. We are not including any lighting poles.



CATEGORY 4

Project Schedule

PROJECT SCHEDULE

29

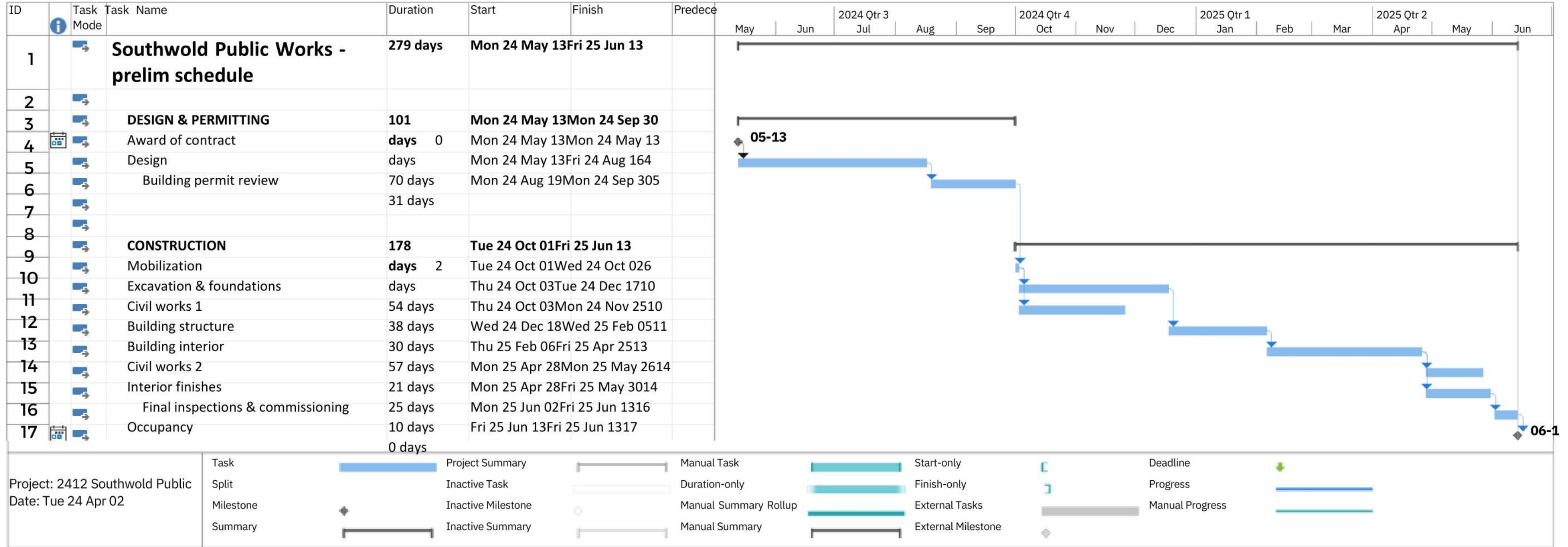

APPENDIX

01_Staff CV's





ELIAS BARIBEAU, GSC

VP Operations | Sr. Project Manager

Elias is a dedicated construction professional with a lifelong passion for building and a proven track record of success in the industry. Beginning his journey in 2007 as a general laborer with Baribeau Construction, Elias has steadily advanced through the ranks to become a skilled carpenter, site supervisor, and ultimately, a proficient Project Manager. Elias' hands-on experience in the field has provided invaluable insights into construction, and now he applies those lessons to successfully quarterback projects from design to completion.

When Elias is not managing his team of construction professionals, he is tending to his hobby farm with his wife and three children or competing in a precision riflery match throughout Ontario.

PROFESSIONAL EXPERIENCE

Partner at Baribeau Construction - 3 years
Project Manager and Estimator - 13 years
Site Supervision and Carpentry - 6 years

SKILLS

- Project Management
- Cost Estimation
- Budgeting and Financial Analysis
- Team Leadership and Development
- Contract Negotiation
- Risk Management
- Schedule Planning and Management
- Construction Safety Compliance
- Vendor and Supplier Relations
- Ontario Building Code Knowledge
- Site Supervision

EDUCATION

Drafting and Design Certificate
Fanshaw College (London, Ontario)

SOFTWARE PROFICIENCIES

- AutoCAD
- Bluebeam
- Revit
- Microsoft Office Suite
- Site Max

CERTIFICATIONS

- Gold Seal Certified Employer
- Gold Seal Certified Project Manager
- BCIN Small Building Designer
- Asbestos Awareness Training
- Site Super Awareness in 5 Steps
- First Aid and CPR

ELIAS BARIBEAU, GSC

VP Operations | Sr. Project Manager

PORTFOLIO PROJECTS

Exhaust Direct	\$3.1 million 15,000 sq ft
Motif Labs	\$3 million 11,000 sq. ft.
Indiva	\$8.6 million 33,000 sq. ft.
Whitecrest Mushrooms.	\$8.4 million 35,967 sq. ft
Mitchell's Soup	\$1.3 million 21,676 sq. ft.
Sante Manufacturing	\$1.5 million 105,000 sq. ft.
BMO Soccer Centre	\$10 million 110,000 sq. ft.
A&L Labs	\$2.8 million 9,580 sq. ft
Mount Salem Christian School	\$10 million 38,000 sq. ft
Flight Exec Centre	\$10 million 90,000 sq. ft.
Elgin Innovation Centre	+\$15 million 1,000,000 sq. ft.
Planet Shrimp	\$6million 70,000 sq. ft.

PROFESSIONAL REFERENCES

A&L Labs

Bob Munro

BMunro@alcanada.com

905-599-6270

Jack Stelpstra

Retire VP - EllisDon

jackstelpstra@gmail.com

519-619-6401

Mount Salem Christian School

Richard Kisuule

richard@rdkaccounting.ca

519-639-3767

Hughie Elliott GSC, CEC.

Render Construction

riccsl@rogers.com

A+LiNK Architecture

Stephen Mawdsley

stephenm@alinkarch.ca

PROFESSIONAL AFFILIATIONS





REID BAYLIFF

Project Manager

Reid Bayliff, an accomplished Project Manager, brings nearly a decade of experience in the Construction industry to the table. Over the past six years, Reid has effectively managed and coordinated a diverse portfolio of ICI projects, leaving his mark on notable endeavors such as the Old Imperial Farmer's Market, A&L Labs, and the Mount Salem Christian School. Beginning his career as a carpenter, Reid seamlessly blended his practical knowledge with a sharp eye for detail and a deep understanding of building science, propelling him to new heights within the organization.

Beyond his professional achievements, Reid is equally dedicated to renovating his own home, volunteering his time with various young adult groups, and nurturing his three children, exemplifying a harmonious blend of expertise, community engagement, and family values.

PROFESSIONAL EXPERIENCE

- +4 years of Project Management
- +3 years of Project Coordination & Drafting
- +2 years of General Carpentry

SKILLS

- Project Management
- Cost Estimation & Budgeting
- Team Leadership and Development
- Risk Management
- Schedule Planning and Management
- Construction Safety Compliance
- Vendor and Supplier Relations
- Ontario Building Code Knowledge

EDUCATION

Bachelor of Arts General Studies
Fanshaw - Drafting
GED 12

SOFTWARE PROFICIENCIES

- AutoCAD
- Bluebeam
- Revit
- Microsoft Office Suite
- Site Max

CERTIFICATIONS

- Gold Seal Certified Project Manager (4th yr Intern)
- Asbestos Removal
- First Aid & CPR

REID BAYLIFF

Project Manager

PORTFOLIO PROJECTS

Motif Labs	\$3 million 11,000 sq. ft.
Indiva	\$8.6 million 33,000 sq. ft.
Whitecrest Mushrooms.	\$8.4 million 35,967 sq. ft.
Old Imperial Farmers Market	\$1.0 million 18,000 sq. ft.
Sante Manufacturing	\$1.5 million 105,000 sq. ft.
St. Thomas Elgin Social Services	\$200K 2,000 sq. ft.
A&L Labs	\$2.8 million 9,580 sq. ft.
Mount Salem Christian School	\$10 million 38,000 sq. ft.
390 Hudson Dr - Warehouse	\$6.2 million 32,000 sq. ft.
CJ Pink	\$1.7 million 17,000 sq. ft.
Elgin Innovation Centre	+\$15 million 1,000,000 sq. ft.

PROFESSIONAL REFERENCES

A&L Labs

Bob Munro

BMunro@alcanada.com

905-599-6270

Old Imperial Farmer's Market

Terry Dueck

terry@oifm.ca

(519) 319-9210

Mount Salem Christian School

Sherry Peters

Principal@mtscs.ca

519-852-5057

PROFESSIONAL AFFILIATIONS





RYAN BACK

Site Supervisor

Ryan is a seasoned Site Supervisor in the construction industry who brings a wealth of experience and expertise that spans over two decades, comprising over five years of successful site supervision, an impressive 15-year background as a framing and drywall foreman, and three years as a gas fitting and HVAC technician. Ryan's broad experience in construction and his ability to retain knowledge has propelled him into leadership. Ryan thrives on busy jobsites where the action is happening and enjoys overcoming the challenges that projects naturally bring. Ryan is a natural board leader and team player. When away from the jobsite, Ryan is a dedicated baseball coach, passionate outdoorsman, and proud father of four children. Ryan's values as a human add to his ability to relate and lead people on the job site.

PROFESSIONAL EXPERIENCE

+5 years of Site Supervisor experience
+15 years of experience as framing and drywall foreman
+3 years gas fitting and HVAC

SKILLS

- Ontario Building Code
- Site Supervision
- On site Health and Safety
- Light Machinery Operation
- Onsite Resource Management
- Lean Scheduling
- Team Leadership and Development
- Risk Management
- Schedule Planning and Management
- Construction Safety Compliance
- Vendor and Supplier Relations
- Problem Solving
- Emergency Response Planning

EDUCATION

GED grade 12
Fanshaw College - Gas Fitting
Red Seal Certification - Carpentry

SOFTWARE PROFICIENCIES

- Bluebeam
- Microsoft Office Suite
- Site Max

CERTIFICATIONS

- Red Seal Certified Carpenter
- Asbestos Abatement (Type 1 & 2)
- Gold Seal Site Supervisor (4th yr Intern)
- First Aid & CPR
- Forklift & Elevated Platforms Training
- Working at heights

RYAN BACK Site Supervisor

PORTFOLIO PROJECTS

Motif Labs	\$3 million 11,000 sq. ft.
Whitecrest Mushrooms.	\$8.4 million 35,967 sq. ft
Tillsonburg Christian Reformed Church	\$1.9 million 9, 850 sq. ft
Sante Manufacturing	\$1.5 million 105,000 sq. ft.
St. Thomas Elgin Social Services	\$200K 2,000 sq. ft.
A&L Labs	\$2.8 million 9,580 sq. ft
Mount Salem Christian School	\$10 million 38,000 sq. ft
Elgin Innovation Centre	+\$15 million 1,000,000 sq. ft.

PROFESSIONAL REFERENCES

A&L Labs

Bob Munro

BMunro@alcanada.com

905-599-6270

Mount Salem Christian School

Richard Kisuule

richard@rdkaccounting.ca

519-639-3767

Elgin Innovation Centre

Steven Cuthbert

steven@elginnovation.ca

(519) 268-8531

PROFESSIONAL AFFILIATIONS





Travis Parker P.Eng

Principal

Travis is an inventive and enthusiastic professional engineer. He is committed to impactful collaboration, and he knows what it means to make a client's vision come alive.

[contact]

519-681-6475
tparker@co-elevate.ca

[education]

Bachelor of Engineering Science –
Civil Engineering
University of Western Ontario

[accreditations]

Professional Engineers Ontario

Northwest Territories Association
of Professional Engineers and
Geoscientists

[charity involvement]

Regular Blood donor to Canadian
Blood Services

Salvation Army Christmas Kettle
Volunteer

[project highlights]

Ritz Lutheran Long Term Care Addition

This building is a 68,000 square foot two storey facility addition to the existing facility located in Mitchel, Ontario

Jefferson Elora Corporation Expansion

This building is a 75,000 square foot addition to the existing JEC plant in Elora, Ontario

Nestle Facility Expansion

This building is a 24,000 square foot steel and concrete addition to the north and south of the existing plant in London, Ontario

Retail Pad Development

This new pad development site included a 2,300 square foot Dairy Queen and 4,600 square foot retail building in Aylmer, Ontario

Iqaluit 6 Row

This new 5500 square foot two storey residential development included 6 row homes in Iqaluit, Nunavut

International Name Plate Supply Expansion

This building is a 35,000 square foot Pre-Eng addition to the east of the existing plant in London, Ontario

Nuvo Property Management Parking Garage Rehabilitation

Rehabilitation of existing parking garage including concrete repairs and waterproofing membrane replacement



Steve Desjardine C.E.T.

Partner

Steve is an enthusiastic certified engineering technologist with a keen eye to detail and commitment to making a client's vision come to life.

[contact]

519-681-6475
sdesjardine@co-elevate.ca

[education]

Diploma: Architectural Technology
Fanshawe College

[accreditations]

Ontario Association of Certified
Engineering Technicians and
Technologists (OACETT)

[charity involvement]

Canadian Cancer Society
Childcan
Habitat for Humanity
Construction

[project highlights]

Ritz Lutheran Long Term Care Addition

This building is a 68,000 square foot two storey facility addition to the existing facility located in Mitchell, Ontario

Canada Southern Station

The Canada Southern Station (CASO) is a historical train station in the Railway Capital of Canada, St. Thomas, ON.

Lamplighter Inn Best Western

This expansion to an existing hotel chain, is 100,000 square feet, in London, Ontario

Brouillette Manor LTC Home

This new Long Term Home is 58,000 square feet, located in Windsor Ontario, currently under construction

BOS Innovations

This new 55,000 square foot hi-tech industrial facility is located in London, Ontario

Village of Tansley Woods I, II , and III

This building is an eight and 3 storey retirement, and Long Term Care Facility is located in Burlington, Ontario

Trillium Villages Affordable Housing

This proposed development of 64 affordable housing units and Clubhouse is located in Strathroy, Ontario



MISSION

Capturing **Vision** Through
Construction

VALUES

Do the right thing
Strive for excellence
Embrace the challenge
Be client focused
Put family first
Work as a **team**

INFO@BARIBEAUCONSTRUCTION.COM | (519) 268-8343



BARIBEAU
CONSTRUCTION
— EST. 1987 —

**CAPTURING VISION
THROUGH CONSTRUCTION**



Appendix A

Proposal Form

Proposal Form

Design and Construction of the Southwold Public Works Operations Centre

CLOSING:

LOCATION: The Township of Southwold
35663 Fingal Line,
Fingal ON N0L 1K0

DATE / TIME: Bids shall be submitted before:

April 12, 2024, 2:00 PM local time

Proposal Salutation

To: Aaron VanOorspronk

Deputy of Infrastructure & Development Services

Request for Proposal for Design-Build Services

Southwold Public Works Operations Centre, RFP NO. 2024 PW-002

From:

This proposal is submitted by:

Firm Name: Baribeau Construction (London) Limited

Address: 10 Stardust Drive, Dorchester, ON, N0L 1G5

Telephone: 519-268-8343

Facsimile: _____

Email: elias@baribeauconstruction.com

1. Proposal Obligations and Representations

- 1.1 The Proponent declares that no person, firm or corporation other than the one whose signature or the signature of whose proper officers and seal is, or are attached below, has any interest in this Proposal or in the contract proposed to be undertaken. There is no conflict of interest.
- 1.2 The Proponent declares that this Proposal is made without connection, knowledge, comparison of figures or arrangements with any other person, firm or corporation making a proposal for the same work and is in all respects fair and without collusion or fraud.
- 1.13 The Proponent declares that no member or officer of the Township's team, is or will become interested directly or indirectly as a contracting party or otherwise in or in the performance of the contract, or in the supplies, work or business to which it relates or in any portion of the profits thereof, or of any such supplies to be used therein or in any of the monies to be derived therefrom.
- 1.4 The Proponent declares that the matters stated in this Proposal are in all respects true.

1. The undersigned Proponent proposes and agrees, if this Proposal is accepted, to enter into negotiations with the Township to negotiate an agreeable contract to perform all Work as specified and quoted for in this form of proposal and within the Time indicated in this Proposal and in accordance with the other terms and conditions of the RFP Documents and as accepted by the Township. A CCDC 14-2013 Design-Build Stipulated Price Contract will be used as the basis for negotiations.

This Proposal deliver documents required by the Request for Proposal and Proposal Form within **ten business days** after the date of Township's Notice of Award.

In submitting this Proposal, the Proponent represents and agrees that:

- a) The Proponent has examined and carefully studied the Proposal Documents and the following Addenda (*receipt of all which is hereby acknowledged, proponent to list Addendums received.*)

Addendum No.	Addendum Date:
Addendum #1	2024-03-21
Addendum #2	2024-04-05
Addendum #3	2024-04-08

- b) The Proponent has visited the Site and become familiar with the general, local, and site conditions that may affect cost, progress, performance, and furnishing of the Work.

- c) The Proponent is familiar with all applicable federal, provincial and local laws and regulations that may affect cost, progress, performance, and furnishing of the Work.
- d) The Proponent has studied the provided Township's available reports of explorations and tests of site conditions at or contiguous to the Site, and all Township provided available drawings of physical conditions relating to existing surface or subsurface structures at or contiguous to the Site which have been identified to form part of this RFP and made available by the Township.
- e) The Proponent has correlated the information known to the Proponent, information and observations obtained from visits to the Site, reports, and drawings identified in the Proposal Documents, and all additional examinations, investigations, explorations, tests, studies data performed by the Proponent at its own cost as deemed necessary for the purpose of responding to this RFP, with the Proposal Documents.
- f) The Proponent has given the Township written notice of all conflicts, errors, ambiguities or discrepancies that the Proponent has discovered in the Proposal Documents and the written resolution issued by addenda by the Township is acceptable to the Proponent, and the Proposal Documents are generally sufficient to indicate and convey an understanding of all terms and conditions for performing and furnishing the Work for which this Proposal is submitted.
- g) If this Proposal is accepted, the Proponent agrees to furnish bona fide Bonds as required and proof of required insurance coverage as required and to execute four copies of the Contract Documents within **ten calendar days** after being so notified. In the event of default or failure, the Proponent agrees that the Township shall be at liberty to negotiate with others or to accept the next lowest or any proposals or to advertise for new proposals, or to carry out the works in any other way it deems best.
- h) The Proponent having fully examined the conditions relating to the Work and having carefully examined the above-noted documentation submits the attached Proposal and offer to perform the Work in strict accordance with the said documents and such further details, plans and instructions as may be supplied from time to time and to furnish the Township all professional services necessary to carry out and properly complete the Work.
- i) The Proponent certifies that it is in possession of all documents listed in this RFP.

Submitted on April 16, 2024.

If Proponent is a **Partnership**:

By _____ (SEAL)
(Firm Name)

(General Partner)

(Name)

(Title)

(Signature)

Business Address: _____

Phone No.: _____

Email/Facsimile No.: _____

If Proponent is a **Corporation**:

By Baribeau Construction (London) Limited (SEAL)
(Corporation Name)

Ontario
(Province of Incorporation)

Elias Baribeau
(Name of Authorized Person)

VP Operations
(Title)

(Signature)

I have the authority to bind the corporation.

Business Address: 10 Stardust Drive, Dorchester, ON, N0L 1G5

Phone No.: 519-268-8343

Email/Facsimile No.: elias@baribeauconstruction.com

If Proponent is a **Joint Venture**:

By _____ (SEAL)
(Corporation Name)

(Name)

(Title)

(Signature)

By _____ (SEAL)
(Corporation Name)

(Address)

Business Address: _____

Phone No.: _____

Email/Facsimile No.: _____



Appendix B

Pricing Form

Appendix B

Pricing Form

The cost of the building is to include but is not limited to, all design, drawing preparation (including five copies of stamped engineered drawings), permitting, all site works, all service connections and upgrades (unless noted otherwise), construction of the complete building including all interior and exterior finishes, mechanical systems, electrical systems and other components of the site and facility as described in this RFP or determined through the design process.

Prices shall identify contingencies and HST separately in the pricing chart below. A more detailed breakdown of pricing may be requested through the evaluation process.

All prices must be provided in Canadian dollars and must be all-inclusive including labour costs, material costs, all travel and carriage costs, all insurance costs, all costs of delivery, all costs of mobilization, installation and set-up, and all other overhead, including any fees or other charges required by law.

Disbursements are to be included in the fees below, which include printing, travel, courier services, meals, and any telephone/facsimile charges. Proponents shall also be requested to provide, where applicable, rates for additional work of similar nature believed not to be covered in this RFP but considered necessary for the completion of the project and shall specifically identify them in the proposal.

Pricing is worth 40 points of the total score. Pricing will be scored as a weighted score against the lowest price (lowest price will received 40 points).

Proponent will complete the Work for the following Lump Sum Contract Prices:

Description	Price
Detailed Design and Drawings to Construction	\$ <u>100,000</u>
Construction of Public Works Facility	\$ <u>3,028,029</u>
Construction of Associated Site Works and Servicing	\$ <u>761,801</u>
Subtotal	\$ <u>3,889,830</u>
HST	\$ <u>505,677</u>
Final Total	\$ <u>4,395,507</u>
Provisional Items	
Design and Construction of 2 additional interior Drive-Through Bays	\$ <u>363,000</u>
Design and Construction of Mezzanine over office	\$ <u>170,450</u>
Optional Item Description	
Option 1: Security system allowance	\$ <u>20,000</u>
Option 2: Add cord reels to 1 bay	\$ <u>17,000</u>
Option 3: Concrete sidewalk & landscaping at entrance	\$ <u>19,500</u>

Note the proponent shall clearly outline the content and deliverables and impact on the schedule for each optional item noted, as described in detail in the proponent’s proposal. Note cost change as a positive number is added cost, cost change as a negative number of figures in (xx) brackets is a decreased cost to the base amount, all options are pre-tax amounts.



TOWNSHIP OF SOUTHWOLD

Report to Council

MEETING DATE: April 29th, 2024

PREPARED BY: Aaron VanOorspronk, Director of Infrastructure and Development Services

REPORT NO: ENG 2024-31

SUBJECT MATTER: Award of Organics Processing

Recommendation(s):

THAT Report ENG 2024-31 relating to the Award of Organics Processing, be received for information; and

THAT Council approve and award Convertus Canada Ltd. The contract for organic waste processing.

Purpose:

This report seeks Council award of a twenty-year contract with Convertus Canada Ltd. for the processing of organic waste from the Green Bin Program.

Background:

At its meeting on April 8th, Council directed Staff to prepare a 20-year contract with Convertus Canada Ltd. For the processing of organic material generated as part of the Township's new Organics Collection Program. Convertus has drafted up a contract based on the previously discussed terms, the agreement is attached as Appendix A.

Comment/Analysis:

The agreement is very straightforward consisting of only three pages, it outlines the various clauses by which material will be received and processed. The pricing will start at \$80 per tonne escalate by CPI until the fifth year of the contract, at which point it will match the market rate. Previously Council had approved a straight-line adjustment to the market rate over five years, as to not shock the users of the program in the fifth year. The agreement also contains an exit clause, which only requires 60-day notice by either party. Staff have no concerns with the contract.

Financial Implications:

Costs for the program will be recovered by a user fee, as outline in report ENG 2024-27 Organics Processing Contract.

Strategic Plan Goals:

The above recommendation helps the Township meet the Strategic Plan Goal of:

- Managed Growth
- Welcoming and Supportive Neighbourhoods
- Economic Opportunity
- Fiscal Responsibility and Accountability

**Respectfully Submitted by:
Aaron VanOorspronk, CET.
Director of Infrastructure and
Development Services
"Submitted electronically"**

**Approved by:
Lisa Higgs, CAO/Clerk
"Approved electronically"**

ORGANIC WASTE PROCESSING AGREEMENT

THIS AGREEMENT is made this 19th day of April, 2024, BETWEEN: **Corporation of the Township of Southwold**, a township corporation with its head office located at 35663 Fingal Line, Fingal Ontario, N0L 1K0 (hereinafter referred to as "Customer"), AND: **Convertus Canada Ltd.**, a corporation incorporated under the laws of Ontario with its head office located at 8-307 Commissioners Road West, London ON, N6J 1Y4 (hereinafter referred to as "Service Provider").

WHEREAS the Customer is responsible for the collection of organic waste within its jurisdiction; and

WHEREAS the Service Provider is engaged in the business of receiving and processing organic waste;

NOW, THEREFORE, in consideration of the mutual covenants and agreements hereinafter set forth, the parties hereto agree as follows:

1. SCOPE OF SERVICES

The Service Provider shall receive and process all organic waste collected by the Customer. The term "organic waste" shall be defined as food waste collected in the municipal green bin program.

2. TERM

The term of this Agreement shall commence on May 15, 2024, and shall continue for a period of twenty (20) years unless earlier terminated as provided herein.

3. PRICING

The Customer agrees to pay the Service Provider a fee of \$80 per tonne of organic waste processed in the first year of the Agreement. Thereafter, the price shall increase annually in accordance with the Consumer Price Index (CPI) until the fourth year of the contract. Beginning in the fifth year of the contract, the price shall adjust to an agreed-upon market rate, with Convertus Canada Ltd. presenting evidence of current market rates leading up to contract year five.

4. EXCLUSIVITY

During the term of this Agreement, the Customer agrees to deliver all organic waste collected by it exclusively to the Service Provider.

5. CONTAMINATION CLAUSE

For the purposes of this Agreement, "Contamination" shall be defined as the presence of in-organic material within the load of Organic Waste. If contamination is deemed higher than 10% by visual inspection, the Service Provider shall take a photo of the load, share it with the Customer, then dispose of the load at a landfill, charging the Customer the tip fee plus the cost of disposal at the landfill to compensate for the additional time and effort for the contaminated load.

6. DEFINITION OF TIP FEE

"Tip Fee" shall refer to the Fee for the acceptance and processing of Organic Waste as defined within this Agreement.

7. PAYMENT TERMS

The Service Provider shall invoice the Customer monthly for Organic Waste processed in the month prior. Payment terms shall be net 30 days from the date of the invoice.

8. DELIVERY REGIME

The Customer agrees to biweekly delivery of Organic Waste, to be carried out on the same day of the week each time. Should a scheduled delivery day fall on a recognized holiday, the delivery may be pushed to the next business day.

9. OWNERSHIP OF GREENHOUSE GAS CREDITS

Any and all carbon credits, greenhouse gas offsets, or similar benefits derived from the processing of Organic Waste under this Agreement ("Carbon Credits") shall be the sole property of Convertus Canada Ltd.

10. DISPUTE RESOLUTION

In the event of any dispute arising out of or relating to the adjustment of fees in year 5 of this Agreement, the parties agree to first attempt to negotiate a resolution. If negotiation is unsuccessful, the dispute shall be submitted to arbitration in accordance with the Arbitration Act of Ontario. The decision of the arbitrator shall be final and binding upon the parties.

11. MUTUAL TERMINATION

Either party may terminate this Agreement for convenience upon giving the other party sixty (60) days written notice.

12. GOVERNING LAW

This Agreement shall be governed by and construed in accordance with the laws of Ontario.

13. ENTIRE AGREEMENT

This Agreement constitutes the entire agreement between the parties with respect to the subject matter hereof and supersedes all prior agreements, understandings, negotiations, and discussions, whether oral or written, of the parties.

Signature Page Follows

IN WITNESS WHEREOF, the parties hereto have executed this Agreement as of the first date written above.

CUSTOMER (Corporation of the Township of Southwold):

By: _____

Name: **Grant Jones**

Title: **Mayor**

Date: 2024/04/29

SERVICE PROVIDER (Convertus Canada Ltd.):

By: _____

Name: **Mike Leopold**

Title: **CEO**

Date:



TOWNSHIP OF SOUTHWOLD

Report to Council

MEETING DATE: April 29, 2024

PREPARED BY: Michele Lant, Director of Corporate Services/Treasurer

REPORT NO: FIN 2024-11

SUBJECT MATTER: 2024 Annual Repayment Limit

Recommendation:

THAT Council receive Report FIN 2024-11 2024 Annual Debt Repayment Limit for information.

Purpose:

To provide Council with the 2024 Annual Debt Repayment Limit report prepared by the Ministry of Municipal Affairs and Housing.

Background:

The Ministry of Municipal Affairs and Housing provides each municipality its Annual Repayment Limit (ARL) with respect to long term debt and financial obligations. The information is provided in Schedule 81 of the Financial Information Return (FIR) as described in Ontario Regulation 403/02 as amended.

Comments/Analysis:

The Annual Repayment Limit is attached to this report as Appendix "A". The limit for 2024 based on the 2022 FIR is \$3,022,014 (2023 - \$1,466,278) (2022 - \$2,103,727).

This represents the maximum amount which the Township had available as of December 31, 2022, to commit to payments relating to debt and financial obligations.

As this figure is based on 2022 data, before proceeding with additional long-term debt, the Annual Repayment Limit needs to be updated to reflect any changes since 2022.

As of December 31, 2023 the Township had outstanding principal:

	2023	2022	2021	2020
Wastewater Treatment Plant	\$1,582,982	\$1,619,472	\$1,655,354	\$1,725,253
Library	\$40,000	\$50,000	\$60,000	\$70,000
Drainage - ratepayers	\$0	\$2,294	\$4,458	\$6,500
Total	\$1,622,982	\$1,671,766	\$1,719,812	\$1,801,753

Annual Debt Repayment – Principal and Interest for 2023

	Principal	Interest
Wastewater Treatment Plant	\$74,995	\$55,535
Library	\$10,000	
Total	\$84,995	\$55,535
Total Principal and Interest	\$140,530	

Financial Implications:

The first page of the Annual Repayment Limit Report shows the additional amount of borrowing the Township could undertake based on various terms and interest rates. As you can see the amount is quite substantial when amortized over 20 years (\$37.6 million). While having the ability to borrow up to \$37 million is attractive, it is not realistic as the annual repayment would be an additional \$3,017,120/year. This would not be possible based on the Township budgets for Municipal Services, Water and Wastewater.

Strategic Plan Goals:

The above recommendation helps the Township meet the Strategic Plan Goal of:

- Managed Growth
- Welcoming and Supportive Neighbourhoods
- Economic Development
- Fiscal Responsibility and Accountability

Respectfully Submitted by:
Michele Lant, Director of Corporate Services/Treasurer
“Submitted electronically”

Approved by:
Lisa Higgs, CAO/Clerk
“Approved electronically”

2024 ANNUAL REPAYMENT LIMIT

(UNDER ONTARIO REGULATION 403 / 02)

MMAH CODE:	44606		
MUNID:	34024		
MUNICIPALITY:	Southwold Tp		
UPPER TIER:	Elgin Co		
REPAYMENT LIMIT:		\$	3,022,014

FOR ILLUSTRATION PURPOSES ONLY,

The additional long-term borrowing which a municipality could undertake over a 5-year, a 10-year, a 15-year and a 20-year period is shown.

If the municipalities could borrow at 5% or 7% annually, the annual repayment limits shown above would allow it to undertake additional long-term borrowing as follows:

5% Interest Rate			
	(a)	20 years @ 5% p.a.	\$ 37,660,968
	(a)	15 years @ 5% p.a.	\$ 31,367,467
	(a)	10 years @ 5% p.a.	\$ 23,335,187
	(a)	05 years @ 5% p.a.	\$ 13,083,737
7% Interest Rate			
	(a)	20 years @ 7% p.a.	\$ 32,015,254
	(a)	15 years @ 7% p.a.	\$ 27,524,239
	(a)	10 years @ 7% p.a.	\$ 21,225,358
	(a)	05 years @ 7% p.a.	\$ 12,390,852

DETERMINATION OF ANNUAL DEBT REPAYMENT LIMIT

(UNDER ONTARIO REGULATION 403/02)

MUNICIPALITY:

Southwold Tp

MMAH CODE:

44606

		1
		\$
Debt Charges for the Current Year		
0210	Principal (SLC 74 3099 01)	165,488
0220	Interest (SLC 74 3099 02)	268
0299	Subtotal	165,756
0610	Payments for Long Term Commitments and Liabilities financed from the consolidated statement of operations (SLC 42 6010 01)	0
9910	Total Debt Charges	165,756

		1
		\$
Amounts Recovered from Unconsolidated Entities		
1010	Electricity - Principal (SLC 74 3030 01)	0
1020	Electricity - Interest (SLC 74 3030 02)	0
1030	Gas - Principal (SLC 74 3040 01)	0
1040	Gas - Interest (SLC 74 3040 02)	0
1050	Telephone - Principal (SLC 74 3050 01)	0
1060	Telephone - Interest (SLC 74 3050 02)	0
1099	Subtotal	0
1410	Debt Charges for Tile Drainage/Shoreline Assistance (SLC 74 3015 01 + SLC 74 3015 02)	268
1411	Provincial Grant funding for repayment of long term debt (SLC 74 3120 01 + SLC 74 3120 02)	0
1412	Lump sum (balloon) repayments of long term debt (SLC 74 3110 01 + SLC 74 3110 02)	0
1420	Total Debt Charges to be Excluded	268
9920	Net Debt Charges	165,488

		1
		\$
1610	Total Revenue (SLC 10 9910 01)	15,733,492
Excluded Revenue Amounts		
2010	Fees for Tile Drainage / Shoreline Assistance (SLC 12 1850 04)	0
2210	Ontario Grants, including Grants for Tangible Capital Assets (SLC 10 0699 01 + SLC 10 0810 01 + SLC10 0815 01)	1,715,693
2220	Canada Grants, including Grants for Tangible Capital Assets (SLC 10 0820 01 + SLC 10 0825 01)	6,300
2225	Deferred revenue earned (Provincial Gas Tax) (SLC 10 830 01)	0
2226	Deferred revenue earned (Canada Gas Tax) (SLC 10 831 01)	190,505
2230	Revenue from other municipalities including revenue for Tangible Capital Assets (SLC 10 1098 01 + SLC 10 1099 01)	1,180,898
2240	Gain/Loss on sale of land & capital assets (SLC 10 1811 01)	-109,910
2250	Deferred revenue earned (Development Charges) (SLC 10 1812 01)	0
2251	Deferred revenue earned (Recreation Land (The Planning Act)) (SLC 10 1813 01)	0
2256	Deferred revenue earned (Community Benefits) (SLC 10 1815 01)	0
2252	Donated Tangible Capital Assets (SLC 53 0610 01)	0
2253	Other Deferred revenue earned (SLC 10 1814 01)	0
2254	Increase / Decrease in Government Business Enterprise equity (SLC 10 1905 01)	0
2255	Other Revenue (SLC 10 1890 01 + SLC 10 1891 01 + SLC 10 1892 01 + SLC 10 1893 01 + SLC 10 1894 01 + SLC 10 1895 01 + SLC 10 1896 01 + SLC 10 1897 01 + SLC 10 1898 01)	0
2299	Subtotal	2,983,486
2410	Fees and Revenue for Joint Local Boards for Homes for the Aged	0
2610	Net Revenues	12,750,006
2620	25% of Net Revenues	3,187,502
9930	ESTIMATED ANNUAL REPAYMENT LIMIT	3,022,014
		(25% of Net Revenues less Net Debt Charges)

* SLC denotes Schedule, Line Column.



TOWNSHIP OF SOUTHWOLD

Report to Council

MEETING DATE: March 25, 2024

PREPARED BY: Lisa Higgs, CAO/Clerk

REPORT NO: CAO 2024-24

SUBJECT MATTER: Talbotville Street Names – Plans of Condominium

Recommendation:

THAT the Council of the Township of Southwold approves proposed street names for various vacant plans of condominium in Talbotville.

Purpose:

The purpose of this report is to provide information to Council on a proposed street names in Talbotville.

Background:

The Township does not have an official “naming policy”. Attached to this report was a draft naming policy that was brought before Council in 2021, but was never adopted. Staff can bring this policy back (after it has been reviewed and evaluated) if there is a desire from Council to formalize the naming process. In the absence of a formal naming policy, historically street names in new subdivisions are proposed by developers and then brought to Council for approval.

Comments:

At the request of the Developers, Council should consider approving the following street names.

Woodland Way (off of Talbotville Gore Road)- Vacant Land Condominium

The Developer requests that the “street” (will be in private ownership as part of the plan of condominium) be named either Higham Way or Primrose Way.

Talbotville Meadows (off of Optimist Drive) Vacant Land Condominiums

The Developer requests that the “street” (will be in private ownership as part of the plan of condominium) be named as follows:

- Block 177 – Beechgrove Gardens (backup is Hickory Walk) – Sketch below:

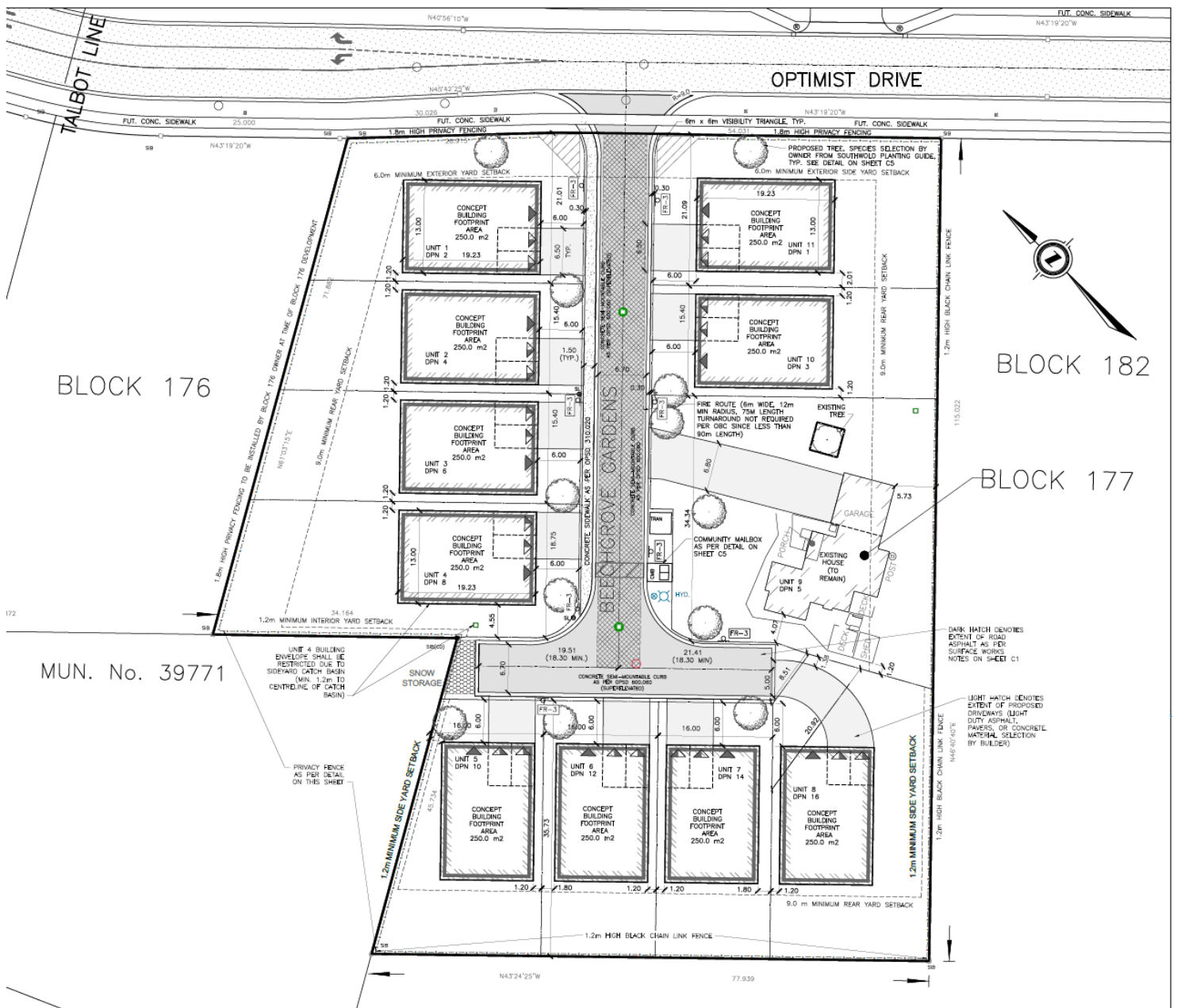

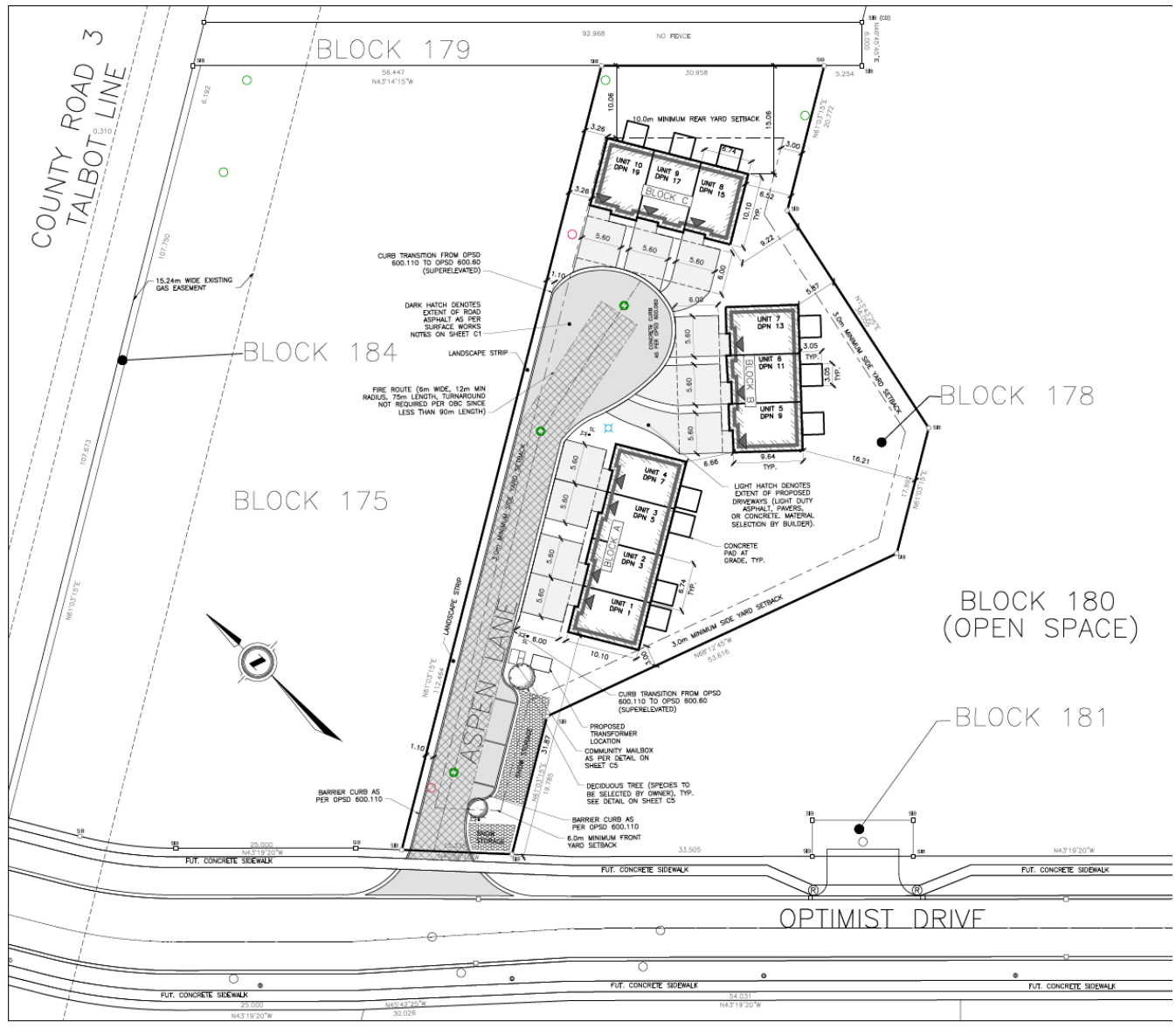

Staff have reviewed the proposals and do not have concerns with the names. We have conferred with Emergency Services and are not aware of duplicate names in the community or in neighbouring municipalities.

Financial Implications:

There are no financial implications.

Strategic Plan Goals:

The above recommendation helps the Township meet the Strategic Plan Goal of:

- Managed Growth.

- Welcoming and Supportive Neighbourhoods
- Economic Development
- Fiscal Responsibility and Accountability.

**Respectfully Submitted by:
Lisa Higgs, CAO/Clerk
"Submitted electronically"**

Policy Statement:

The Township of Southwold is committed to providing a fair, consistent and efficient process while respecting the important need for public consultation and legislative approvals with respect to naming, renaming or dedication of Municipal Assets such as streets, parks, and facilities, as well as the major elements of such municipal assets. On occasion, Southwold Council may wish to acknowledge the activities and significant contributions of a person, persons or family, to the community through the naming of a municipal asset.

Purpose:

This policy establishes the processes and criteria for naming, renaming or dedicating Municipal Assets such as streets, parks, and facilities as well as the major elements of such municipal assets, including the methods by which the public may provide suggestions and comments. This Policy also sets out Council's direction and guidelines with respect to the corporate sponsorship and naming rights of Township programs, services, and facilities.

The main objectives of this policy are:

- To continue the current practice of naming municipal property, buildings and parks after significant geographical, neighbourhood and historical elements;
- To recognize, on an exceptional basis, significant contributions that organizations or individuals have made to public life and the well-being of the people of Southwold;
- To provide direction on how to apply for approval to name, re-name or dedicate municipal street, facility, or park;
- To ensure the application of a defined consultation process to encourage community participation;
- To ensure a clear, efficient and timely naming process;
- To ensure the application of key criteria to determine the validity of a commemorative name;

- To ensure the compilation of a comprehensive Names Registry to act as one central repository for all approved names for streets, parks, and facilities;
- To ensure a proper approval process and the importance of the role of legislative bodies (ie Committee and Council approval) are acknowledged; and
- To provide for a working group that is responsible for developing recommendations with respect to naming of specific municipal assets for Council's consideration.

The policy applies to all Township employees and persons acting on behalf of the Township, as well as members of Council and the public with respect to naming of municipal assets.

Definitions:

For the purpose of this Policy, the following definitions shall apply:

Advertising – The selling or leasing of advertising space on corporate materials (printed and electronic), and signage on Township-owned assets and properties; whereby the advertiser is not entitled to any additional benefits beyond access to the space purchased. Advertising is a straightforward purchase of space based on pre-established base rates and a defined time period.

Commemorative – shall refer to the official naming of a municipal street, park or facility after a person, persons or family name.

Donation(s) – A cash and/or in-kind contribution made to the Township with no reciprocal commercial benefit expected or required from the Township. Donations do not involve a business relationship and are distinct from sponsorship and/or advertising initiatives.

Elements – components of a facility or park, including but not limited to trails, pools, arenas, parking garages, plazas, courtyards, gardens, lawns, recreation fields, wings, halls, auditoriums, galleries, lounges, lobbies, meeting rooms.

Memorials – a discreet memorial such as a tree or a bench in a park or public space, dedicated to a person or group which may include a plaque; does not include flowers, floral arrangements, images, signs, tokens, tributes, religious offerings, ashes, etc.

Municipal Asset – refers to municipal streets, municipally-owned parks and facilities, including major elements thereof.

Municipal Naming Policy

Including Application Forms

Last updated: April 2024

Municipal Facility – refers to Township-owned buildings and their major elements including but not limited to pools, arenas, parking garages, plazas, courtyards, wings, halls, auditoriums, galleries, lounges, lobbies, meeting rooms.

Municipal Names Registry – a central repository of all approved names for streets, parks, and facilities including names submitted that qualify, but may not be chosen by for a particular asset, but that could be considered for future assets. It shall also include records related to the history of the names selected for assets, when previously recorded for use as street names and/or as of the date of implementation of this policy. The Registry includes names of previous Mayors and Council members and the remaining names of Township veterans killed in action, not previously recognized

Naming Rights – refers to the granting by the owner of the right to name a piece of property or portions of a property, typically in exchange for financial consideration.

Parks – shall include parkland, open spaces, valley lands, environmentally-protected areas; references to Parks shall include major elements including but not limited to trails, gardens, lawns, recreation fields, courtyards, plazas.

Sponsorship - A marketing-oriented, contracted arrangement that involves the payment of a fee or payment in-kind by a company in return for the right to a public association with an activity, item, person or property for mutual commercial benefit. Sponsorships may be in the form of financial assistance, noncash goods or a contribution of skills or resources.

General Provisions:

The naming, renaming and dedication of Municipal Assets shall be the responsibility of the Council of the Township of Southwold. Council may, at any time, direct that a specific name be used for a specific street, facility or park or element thereof. The intent of naming is for permanent recognition. The renaming of streets, parks and facilities is strongly discouraged as it significantly impacts numerous individuals, Township departments and the community.

Naming Process:

Naming Principles When a Municipal Asset is named, renamed or dedicated, the following principles shall be applied:

Municipal Naming Policy

Including Application Forms

Last updated: April 2024

- Names shall be unique; name duplication and similar sounding or spelled names shall be avoided.
- Names should give a sense of place, continuity, belonging and celebrate the distinguishing characteristics and uniqueness of Southwold.
- Names should maintain a long standing local area identification with the residents of Southwold.
- Names should promote pride in the Township of Southwold, acknowledge local heritage, history, and recognize unique features and geography (such as names that relate to local history, places, and events, native wildlife, flora, fauna and natural features or unique characteristics of a neighbourhood or area).
- The rationale associated with the use of a particular name shall be understandable to the majority of Township residents;
- Names shall not be discriminatory, derogatory or political in nature; names conveying a secondary negative or offensive connotation, any sexual overtones, inappropriate humour, slang or double meanings shall be avoided.
- The re-use of former street names shall be discouraged to avoid confusion with property records management.
- Names shall assist with emergency response situations by being consistent with street names and geographical locations.
- Names with hyphens, apostrophes or dashes shall be discouraged but may be considered on an individual basis.
- Names may, on an exceptional basis, honour the significant contributions of an individual or family.
- Names may recognize the contributions of organizations such as a partnership with or without financial contributions
- The form of signage shall be consistent with Township signage guidelines.
- The cost associated with a naming/renaming (including but not limited to signage, ceremonial costs, legal costs, etc.) will be the responsibility of the Township when the naming/re-naming has been initiated by the Township and will be the responsibility of the

community or Corporate entity when the naming/renaming has been initiated by the community/Corporate entity.

- The Council of the Township of Southwold makes all final decisions concerning what is placed or occurs on Township property and in its buildings.
- Names associated with a sponsorship will be considered when a donation amount relates to the valuation of the Naming Right for the facility, park or element thereof, in accordance with the Naming Rights section of this policy.
- Naming in honour of elected or appointed public officials, Township administrative officials or staff shall occur posthumously.
- Municipal Assets are not intended to provide the facilities and/or function of memorial purposes normally found at cemeteries
- Council shall retain the right not to name certain facilities of broad community importance such as (but not limited to) Township Office

Prioritization

Priority shall be given to naming, re-naming or dedicating Municipal Assets after:

- the area or street in which the property or building is located to provide a geographical association to help the public to locate a park, bridge or building more easily;
- the most dominant "constant feature either within or nearby" the selected site such as an associated significant ecological or natural resource feature;
- an historical name related to Southwold's heritage and/or historical folklore;
- an event or person of international, national or provincial significance; or
- an organization or individual (with the exception of public officials or Township staff, unless posthumously) to recognize:
 - particular activities and significant contributions to the community; and/or -
 - outstanding contributions and/or sponsorships made toward the development and/or enhancement of a property or building.

Specific Criteria for Commemorative Naming

Where the commemorative naming of a Municipal Asset, is being requested, at least one of the following criteria shall apply:

- The nominated individual shall have demonstrated excellence, courage or exceptional service to the citizens of the Township of Southwold, the County of Elgin, the Province of Ontario and/or Canada, including veterans of military conflicts;
- The nominated individual shall have an extraordinary community service record;
- The nominated individual shall have worked to foster equality and reduce discrimination;
- A direct relationship or association that existed between the place of residence of or community efforts undertaken by the individual and the property, building or element to be named;
- An individual may be recognized for a significant financial contribution to a park or facility, where that contribution significantly benefits the community that the park or facility serves, in accordance with the Naming Rights section of this policy
- The nominated name has historical significance

Where the name of an individual or organization is so used, approval shall be obtained from the individual (his/her family) or the organization for such naming.

Single Use

A commemorative name should only be used once. A single use of a commemorative name shall apply as of the effective date of this policy.

Renaming of Commemoratively Named Assets

The names of Municipal Assets named commemoratively should not be changed unless it is found that the individual's personal character is or was such that the continued use of their name for a park or facility would not be in the best interest of the community.

Municipal Names Registry

All approved names from the Municipal Names Registry for use associated with Municipal Assets will be available publicly. The public listing shall apply to names approved as of the effective date of this policy.

Processes

The naming process for Municipal Assets may involve a different course of action depending on the circumstances surrounding the request/requirement for naming.

A. Process – Suggestions for Adding to the Municipal Names Registry and/or Naming of a Park or Facility

- 1) Receipt of a Nomination/Application: All requests for adding names to the Registry/naming of a Park or Facility are to be submitted in writing by completing the Naming Application Form available as Appendix "A" to this policy document, and all supporting documentation as may be required.
- 2) Processing of the Nomination/Application: Processing the application involves confirmation of criteria, discussion with the applicant and the applicable Township departments/external stakeholders including Emergency Services, public consultation for a 30-day period, compiling consultation results and a convening meeting of the Municipal Naming Working Group for a review of the public consultation results. In cases where there is no opposition received during the public consultation period, a report may be submitted directly to Council. Opposition is defined as a clear expression that the name in question does not meet the criteria for as outlined in this policy.
- 3) Report to Council: When a name is recommended for approval, a report to Council is prepared containing the Municipal Naming Working Group's recommendation.
- 4) Implementation of Approved Nomination: Upon Council approval of a recommendation, implementation of the approved name is undertaken. This involves final notification to the nominee and may involve an official unveiling ceremony with the presentation of a plaque or sign to be erected at the site, indicating the name as well as its significance, if the approval includes immediately assigning the name to a specific asset.
- 5) Maintenance of the Municipal Names Registry: Names that are approved by Council shall be placed on the Municipal Names Registry along with all records related to the history of the approved name. Where an approved name is not assigned to a specific asset immediately, it shall remain on the Registry for future use.

B. Process - Naming of a Street

- 1) Receipt of a Proposed Street Names: Township staff receives a written request by the proponent or developer for a name(s) which includes the proposed street name(s) and a brief but complete explanation of the significance of the name, as per the conditions of development approval. In the absence of a specific theme or choices by the developer or proponent, staff will provide options for names available for use from the Municipal Names Registry and request their choice.
- 2) Processing of the Street Name Request: Processing the application involves confirmation of criteria, discussion with the proponent or developer and the applicable departments/external stakeholders including Emergency Services. A meeting of the Municipal Naming Working Group may be held but will not be required for the naming of a street. Public consultation shall not be required for the naming of a street. The Township shall inform the developer if the name is known to conflict with existing street names at either the local or county level or is otherwise unacceptable to any of the parties consulted and shall provide the reason why the name is not acceptable. The Street Type designations shall be applied in accordance with the Appendix B to this policy. Where a request for a commemorative street name has been made, the name will be vetted through the investigation and criteria evaluation process of this policy and the processing may include consultation with the Municipal Naming Working Group.
- 3) Assigning Name from the Municipal Names Registry: Where the proponent is also the owner or developer of a project, a name from the Municipal Names Registry may be reserved for use in that particular development. The proponent reviews an up-to-date Municipal Names Registry for the name(s) selection, including names approved by Council specifically for use within the proponent's project. Street Type designations shall be applied in accordance with the Appendix B to this policy.
- 4) Approval of Names: A report is presented to Council using the suggested street name(s) after consultation with the Municipal Naming Working Group for approval.

- 5) Implementation of Approved Nomination: Upon passage of a road opening, naming, and establishing by-law, implementation of the approved name is undertaken. This involves final notification to the developer and may involve an official unveiling ceremony with respect to commemorative names, with the presentation of signage to be erected at the site. Special signage containing the Poppy symbol shall be used to recognize all streets named in honour of veterans.
- 6) Maintenance of Municipal Names Registry: Township staff shall maintain records related to the history of the approved street names. Names that are approved by Council without assignment for a specific street shall be placed on the Registry and shall be available for future use.

Public Consultation

Notice/public consultation shall be undertaken in accordance with the size and scope of the Municipal Asset being named, and in consultation with Members of Council. The public consultation period shall last a minimum of 30 calendar days. Public consultation shall not be required for the naming of a street. Written submissions and/or petitions received during the public consultation phase must be verifiable. To that end:

- Each written submission must include the submitter's full first and last name;
- Petitions must be addressed to the Township of Southwold and request a particular action within the authority of Council;
- Petitions must be legible, typewritten or printed in ink;
- The text of a petition must be listed at the top of each page for multiple-page petitions. Pages should be numbered and the total number of pages indicated;
- A petition must be appropriate and respectful in tone, and must not contain any improper or offensive language or information;
- Each petitioner must print and sign his/her own name. A paper petition must contain original signatures only, written directly on the petition;
- Each petitioner must provide his or her full address

- For electronic petitions, petitioners must provide name, address and a valid e-mail address; and
- A petition must clearly disclose on each page that it will be considered a public document and that the information contained in it may be subject to the scrutiny of the Township and other members of the general public. Township staff will provide the final decision on a proposal to individuals who submit a comment under the public consultation component, if requested, and provide a copy of the Commemorative Naming policy and information sheet, when necessary.

Municipal Naming Working Group

The Municipal Naming Working Group, a staff-Council working group, is composed of the following representatives:

- Mayor (or designate)
- CAO/Clerk (or designate)
- Township Treasurer (or designate)
- Public Works Superintendent (or designate)

Furthermore, in instances where the proposal is of a "City-wide" nature or significance, the CAO/Clerk may recommend that a chair (or designate) of committee of Council (i.e. Keystone Committee, Parks Committee, etc.) or local service club (Optimist Club, Rosy Rhubarb, etc.) be invited to participate on the Municipal Naming Working Group.

Multiple Names

In instances where multiple names have been submitted for a Municipal Asset, the Municipal Naming Working Group may select one or more proposal(s) to move forward.

The Municipal Naming Working Group supports public consultation in a manner that is dignified for nominees. As such, the Municipal Naming Working Group may expand or narrow the number of proposals for a particular Municipal Asset, as it deems appropriate.

Renaming

The renaming process shall be identical to the naming process and also require City Council as the final authority for approving the proposed Municipal Asset name. However, the renaming an existing commemoration shall be subject to a minimum of a 60-day public consultation period. If an application is intended to displace an existing commemorative name, before a Renaming Application is accepted, the nominator must have written permission from the family or next of kin to be displaced. Where a renaming has been initiated as a result of a development proposal, the proponent may be required to resolve any opposition that may exist to the renaming, prior to the presentation of a report to Council. Public consultation shall be required for the renaming of a street.

Naming Rights

Guiding Principles for Naming Rights:

- All naming rights arrangements must not compromise, influence or alter the corporate goals and priorities of the Township, or diminish the Township's public image or commitment to inclusiveness.
- Naming rights arrangements must enhance the delivery or general public awareness of Township services or activities and complement the public relations and visual identity of the Township.
- Naming rights arrangements must comply with all federal and provincial statutes, municipal by-laws, and corporate policies and procedures.
- Managing naming rights arrangements should not require disproportionate administrative resources.
- Display of naming rights must not take precedence over the display of the Township's corporate identity on its facilities and must not incur added risks to safety.
- Timeframe for naming rights will be established.

Restrictions for naming rights

- The Township will not solicit or accept sponsorships, naming rights or advertising sales from companies whose reputation could prove detrimental to the town's public image.
- The Township will not allow sponsorships, naming rights or advertising, either directly or through third party arrangements that:
 - Promote consumption of alcohol, marijuana and addictive substances, at events or venues geared primarily to children
 - Promote the sale of tobacco
 - Promote pornography
 - Promote the support of or involvement in the production, distribution, and sale of weapons and other life-threatening products
 - Present demeaning or derogatory portrayals of individuals or groups or contain any message that is likely to cause deep or widespread offence

Council may at its discretion overrule the established criteria.

Naming Rights Solicitation

The Township will consider interest from potential sponsors for naming rights for specific Township assets.

Where appropriate, the Township may issue a Request for Proposal (RFP) for a fundraising feasibility study for naming rights of a specific Township facility in accordance with the Township's purchasing by-law.

The Township will provide potential individuals, organizations or corporations seeking naming rights with details regarding the value of the contribution, including official recognition such as signage and other specifications.

Naming rights must not negatively affect the reputation and integrity of Township properties. The Township will undertake and keep a record of due diligence research and examination of the background and financial condition, business operations and contractual obligations of the potential sponsor.

Naming Rights Evaluation

- All naming rights arrangements will be evaluated against established criteria. The Township may solicit the expertise of an outside firm to assess the costs and benefits of the proposal.
- In evaluating naming right opportunities, commissioners and/or department directors will consider the following factors:
 - Whether the department has sufficient resources (staff and financial) to maximize the benefit of the naming right arrangement without compromising the effective delivery of municipal services and goals of the Township;
 - Whether the naming rights opportunity enhances the Township's image;
 - Whether the opportunity considers and reflects existing naming rights arrangements; and
 - Whether the sponsor is in good standing with the Township.

Naming Rights Agreements

All naming rights arrangements must be confirmed by a written agreement outlining the benefits, roles and responsibilities, fees, payment schedule, duration and other agreed terms of the naming rights arrangement. Departments must maintain records of these agreements, including receipts.

All naming rights arrangements should be evaluated by relevant departments on an annual basis to determine continued benefit.

The Township reserves the right to terminate an existing naming rights arrangement should conditions arise that make it no longer in the best interests of the Township.

Naming Rights Approval

Naming rights agreements for municipal assets require Council approval.

Other

A Member of Council may also request that the Municipal Naming Working Group address other commemorations such as the naming of other public features or public spaces. A Member of Council may also request that the Municipal Naming Working Group conduct public consultation on a name that is not that of a person, persons, or family. Exception In

keeping with its powers set out in the Municipal Act, 2001, Council may assign a commemorative name by resolution, notwithstanding the provisions included in the Municipal Naming Policy.

DRAFT

Appendix "A" to the Municipal Naming Policy
Naming Application Form

A. NOMINATOR'S INFORMATION
Name (Individual or Organization):
Mailing Address:

Telephone:	E-mail:
B. INFORMATION CONCERNING THE PROPOSED NAME	
Proposed Name:	
If the name suggested relates to the commemoration of an individual who is alive, please provide the individual's contact information in the section below. <i>Note: A Commemorative Name may be used only once in the Township of Southwold- subsequent requests will be denied.</i>	
Name:	
Mailing Address:	
Telephone:	E-mail:
<p>Applicable Criteria (select all applicable criteria):</p> <ul style="list-style-type: none"> <input type="checkbox"/> The nominated name gives a sense of place, continuity, belonging and/or celebrates the distinguishing characteristics and uniqueness of Southwold <input type="checkbox"/> The nominated name maintains a long standing local area identification with the residents of Southwold <input type="checkbox"/> The nominated name promotes pride in the Township of Southwold, acknowledges local heritage, history and/or recognizes unique features and geography <input type="checkbox"/> The rationale associated with the selection of the nominated would be understandable to the majority of Southwold residents <input type="checkbox"/> The nominated name recognizes the contributions of organizations such as a partnership with or without financial contribution <input type="checkbox"/> The nominated individual/family has demonstrated excellence, courage or exceptional service to the citizens of the Township of Southwold, The County of Elgin, the Province of Ontario and/or Canada; <input type="checkbox"/> The nominated individual/family has an extraordinary community service record; 	

- The nominated individual/family has worked to foster equality and reduce discrimination;
- A direct relationship or association existed between the place of residence of or community efforts undertaken by the individual/family and the property, building or element to be named;
- The nominated individual has made a significant financial contribution to a park or facility, and the contribution significantly benefits the community that the park or facility serves (i.e., the park or facility may not have otherwise been possible without the financial assistance)
- The nominated name has historical significance

C. RATIONALE

Please describe the rationale for Nomination and attach background information related to criterion chosen, which substantiates all claims made (include copies of newspaper articles, certificates, awards, letters of support or commendation, service records, pictures, etc.)

DRAFT

Please note all information provided below and/or attached to this Application Form will form part of the Naming Application Form and will therefore be released to the public in any public notices/advertisements produced, public Agenda and Minutes, Committee discussions/meetings and Reports which may go forward to Council.

D: DO YOU WISH THE NAME TO BE USED FOR A:

- Park
- Facility/Building
- Street
- Element of a Park or Facility (please describe):
- Any of the above
- Other (please describe):

1st choice:

2nd choice:

E. IS THERE A PARTICULAR PARK/FACILITY/STREET YOU WISH THE NAME TO BE USED FOR?

1st choice:

2nd choice:

F: RENAMING: (Please note that before a Renaming Application is accepted, the nominator must have written permission from the family or next of kin —if this application results in a request to displace an existing commemorative name [person, persons, or family]):

- Does the venue currently have a name? Yes
- No

If yes, provide current name, details and rationale for the proposed renaming of this venue:

G. ADDITIONAL INFORMATION: (ADD INFORMATION AS NEEDED)

Nominator's Signature:	Date:
<i>Personal information about the Nominator contained on this form is collected pursuant to the Municipal Freedom of Information and Protection of Privacy Act, M.56, R.S.O. 1990 and will be used for the purposes of responding to your request. Questions about this collection should be directed to: the City Clerk, City of Barrie, 70 Collier Street, Barrie, Ontario, L4M 4T5, (705) 739-4204</i>	

TO BE COMPLETED BY THE NOMINATOR OR NEXT OF KIN TO THE
NOMINEE FOR COMMEMORATIVE NAMING OF AN INDIVIDUAL
(APPLICABLE IF THE NOMINEE IS DECEASED)

AFFIDAVIT OF _____

(Nominator or Next of Kin)

I, _____, of the Township of Southwold, in the Province of Ontario,
MAKE OATH AND SAY THAT TO THE BEST OF MY KNOWLEDGE, _____ (Name of
Nominee):

1. Was never convicted of an offence as set out in a Federal Statute.
2. Does not have any outstanding convictions or infractions as set out in the *Provincial Offences Act* and/or any Township of Southwold Municipal By-laws.
3. I make this Affidavit in support of the Application Form for the Naming Policy, Township of Southwold, and for no improper purpose.

SWORN/AFFIRMED BEFORE ME at the Township of Southwold, in the County of Elgin, in the Province of Ontario, this _____ day of _____, 20__

A Commissioner, etc

Nominator Or Next Of Kin

Appendix "B" to the Municipal Naming Policy

Street Name Type Designations

The following street type designations shall be applied for the purpose of street naming, as illustrated in the diagram below:

Street, Drive, Avenue, Road, Boulevard - Applicable to major thoroughfares or streets several blocks in length.

Crescent - Applicable to streets forming a crescent.

Court - Applicable to streets that end in a Bulb/cul-de-sac, a "T" or a design that allows turning around and only has one access point.

Gate - Applicable to streets that are short in length and no other streets intersect them.

Lane - Applicable to private streets that would be found in a condominium or townhouse development.

Trail, Way - Streets that are winding or curved in nature.

Terrace, Garden, Grove, Pathway, Heights - Applicable to minor or short streets.

Lane, Mews - Applicable to minor or short length streets

Street Name Layout

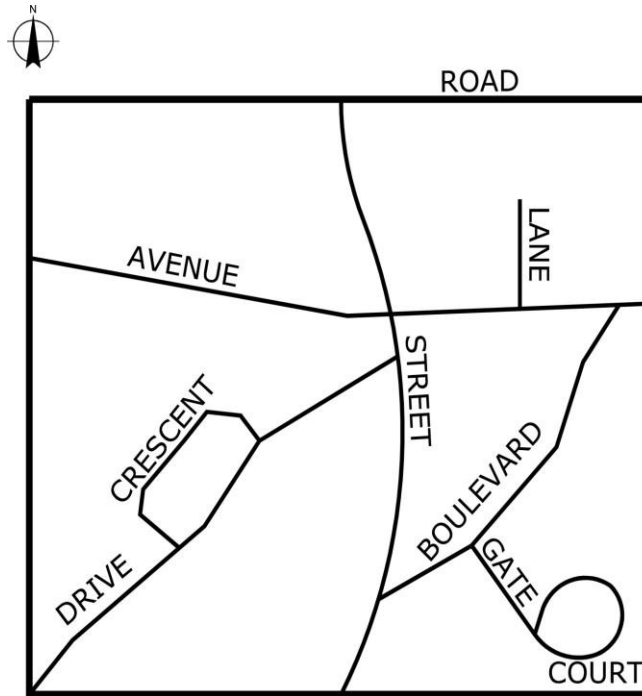

DRAFT



TOWNSHIP OF SOUTHWOLD

Report to Council

MEETING DATE: March 25, 2024

PREPARED BY: Lisa Higgs, CAO/Clerk

REPORT NO: CAO 2024-25

SUBJECT MATTER: Organics Program Policy

Recommendation:

THAT the Council of the Township of Southwold approves the Organics Program Policy;

AND THAT Council extends the Green Bin Collection program and weekly garbage collection to 30 homes located on Major Line and Ford Road, immediately adjacent to the Ferndale Meadows Subdivision.

Purpose:

The purpose of this report is to provide information to Council on the policy drafted for the Organics Policy, including the sale of composters to all residents, allocation of digesters in rural areas, and the green bin collection program in Talbotville and Ferndale. The attached policy provides a summary of decisions made by Council to date with respect to the municipality's organics program.

Background:

The Township's Organic Composting Program aims to improve services to residents and ultimately improve our diversion rate to the landfill, specifically with respect to organic material. The program is evolving and has been informed by the municipality's Zero Waste Committee and adapts as funding for various elements of the program become available.

The policy contains guiding principles which inform elements of the municipality's program:

- The Township recognizes that rural residents and those in settlement areas have distinct characteristics and may need different approaches in each distinct area; a preferred solution in the villages may not be the best solution for our agricultural property owners

- Organic diversion via green bin collection programs are only available to residential properties that currently receive weekly garbage collection
- Organic diversion should be completed in a cost-effective manner for all residents and user fees should be nominal
- Users who benefit from a service level that is not available to all residents may be asked to pay a user fee for that additional service level
- Organic diversion should be flexible and provide a variety of options to residents that may include Green Bin and curbside collection, on-site composting bins, and food digesters
- Organic diversion should not create nuisance issues
- Organic diversion should be coupled with common sense approaches to reduce greenhouse gas emissions. Where on-site organic diversion is available, it is recognized that this has the greatest potential to reduce greenhouse gas emissions, instead of hauling organics to landfills.

The policy also contains specific information and policy direction to achieve consistency on the implementation of composters available for sale to all residents, free food digesters to rural residents outside of the green bin program, and those properties in Ferndale and Lynhurst with green bin collection.

Comments:

Attached to this report, is the Township of Southwold Organic Program Policy.

In the roll-out of the Green Bin program, operations staff became aware that there are a series of residential properties (approximately 30) on Major Line and Ford Road immediately adjacent to Ferndale Meadows & Lynhurst that are not part of weekly collection. Many of these residents have requested that they also be permitted to participate in the Green Bin Program.

Council may consider a few options for these properties:

- 1) Continue with Bi-Weekly Collection and exclude the properties from the Green Bin Collection Program
- 2) Extend the settlement area collection area for Weekly Collection and include the properties in the Green Bin Collection Program.
- 3) Continue with Bi-Weekly Collection BUT include the properties in the Green Bin Collection Program

Staff recommends that the extension of the collection area and transition to weekly collection while providing access to the Green Bin Collection program to Major Line and Ford Road meets the intention and guiding principal of aligning service levels for settlement areas, instead of the options proposed for more rural properties.

A map of these properties is below:

Areas in **BLUE** receive WEEKLY collection and are part of the Green Bin Collection
Areas in **GREEN** receive BI-WEEKLY Collection and are not part of the Green Bin Collection.

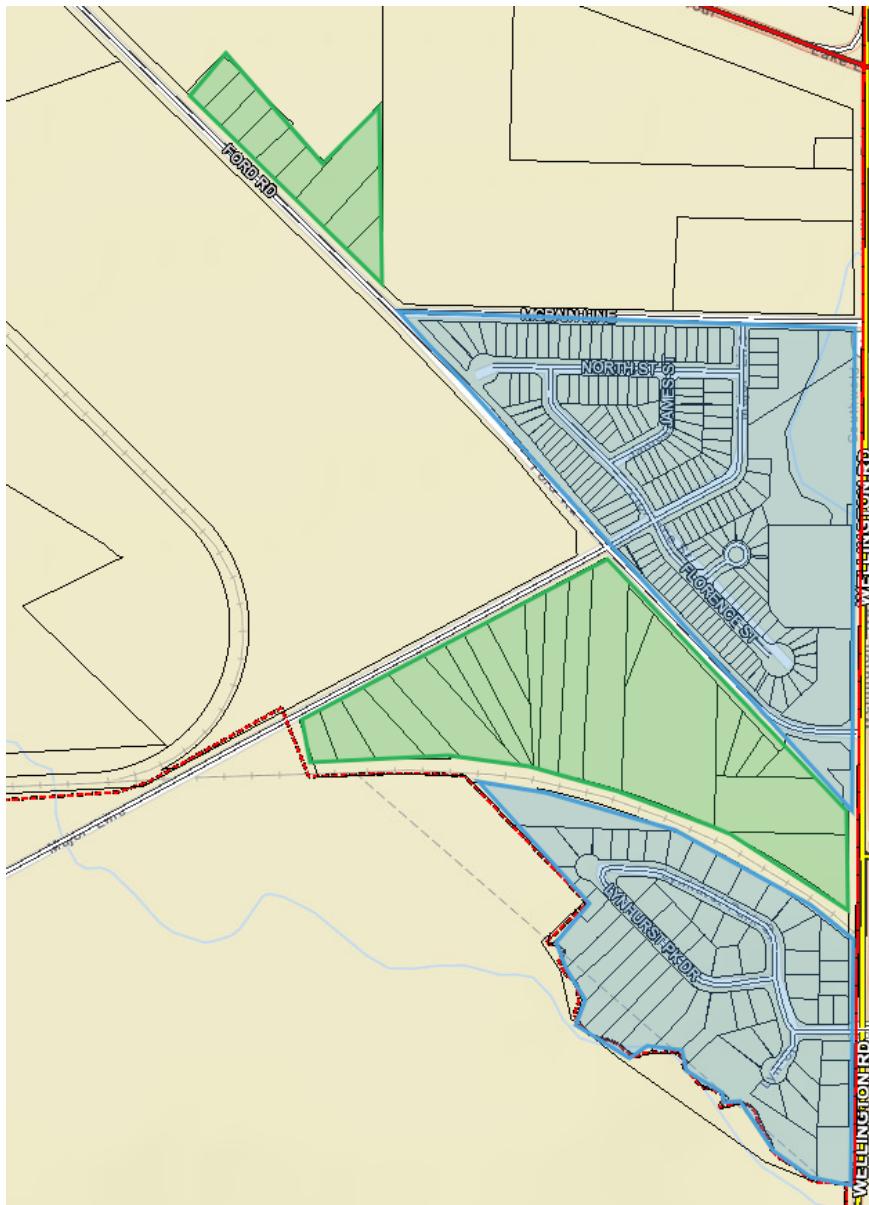

Financial Implications:

The Township organics program has been included in the Township's operating budget and supported by contributions from the Green Lane Community Trust.

With the introduction of an organic collection program for the Talbotville Land Use area, the residents in this area will be charged a special area rate, given that they benefit from an additional service level. For 2024, this special area rate will be: \$70.84/year

Strategic Plan Goals:

The above recommendation helps the Township meet the Strategic Plan Goal of:

- Managed Growth.
- Welcoming and Supportive Neighbourhoods
- Economic Development
- Fiscal Responsibility and Accountability.

**Respectfully Submitted by:
Lisa Higgs, CAO/Clerk
"Submitted electronically"**



Township of Southwold Organics Program

Purpose and Goals:

The Organic Composting Program aims to improve services to residents and ultimately improve our diversion rate to the landfill, specifically with respect to organic material.

Guiding Principles:

- The Township recognizes that rural residents and those in settlement areas have distinct characteristics and may need different approaches in each distinct area; a preferred solution in the villages may not be the best solution for our agricultural property owners
- Organic diversion via green bin collection programs are only available to residential properties that currently receive weekly garbage collection
- Organic diversion should be completed in a cost-effective manner for all residents and user fees should be nominal
- Users who benefit from a service level that is not available to all residents may be asked to pay a user fee for that additional service level
- Organic diversion should be flexible and provide a variety of options to residents that may include Green Bin and curbside collection, on-site composting bins, and food digesters
- Organic diversion should not create nuisance issues
- Organic diversion should be coupled with common sense approaches to reduce greenhouse gas emissions. Where on-site organic diversion is available, it is recognized that this has the greatest potential to reduce greenhouse gas emissions, instead of hauling organics to landfills.

Composters:

Composting is the process of breaking down organic material (yard and food waste) into a dark, nutrient-rich soil that can then be used to help your gardens and flower beds grow.

Composters that provide for on-site organic management are available to all residents in Southwold. The Township sells an above ground composter with a 311 litre capacity at a price of \$25.00, which is subsidized by a grant from the Green Lane Community Trust Fund.

Organic Composting Program

Since composters have been available for purchase for \$25.00 since 2020, reducing the cost in 2024 may not be fair to the residents who had previously purchased them; it is not recommended to reduce the composter costs in the wake of the introduction of digesters and green bins.

Food Digesters or “Green Cones”:

Food waste digesters are the easiest way to compost any type of kitchen scraps, including hard to manage kitchen waste like meat, breads, dairy and processed foods.

While other methods of composting rely on a balance of materials and aeration to work properly, this system does not. Instead, the digester uses heat from the sun and microbial activity to develop a rapid decomposition process, producing a nutrient-rich leachate that is absorbed into the soil. The digester is an aerobic process (with air). Food digesters are an underground composter which is able to digest up to 1 kilogram of food waste every 1-2 days. Digesters do not produce soil in the same method as conventional composters, but instead allow organic waste to break down and digest to slowly be leached into the soil, entirely underground, preventing rodents or other pests.

All residents outside of the Talbotville Settlement Area (as defined in the Official Plan) can acquire one FREE food digester per property. Additional food digesters are available at a price of \$20, per container, which is subsidized by a grant from the Green Lane Community Trust Fund.

Given that residents in the Talbotville Settlement Area (which includes the communities of Lynhurst and Ferndale) are serviced by the Green Bin Collection Program, food digesters are not available for free but can be purchased for \$20 at the municipal office. Digesters are available to rural residents on a request basis and are available for pickup at the municipal office. One digester is available per property. The Township will deliver digesters to residents with vehicles that are too small to transport digesters, within a two week period of the residents requesting them, in an effort to coordinate multiple deliveries at once to find efficiencies.

Green Bin Collection:

Beginning on May 1 2024, the urban green bin collection program was initiated in the Talbotville Settlement area, which includes the communities of Talbotville, Ferndale and Lynhurst.

Initial, fully assembled green bins will be delivered to residential properties by Public Works staff during the month of March 2024, which will include communications products attached to the bins, to residents explaining the collection program.

Green Bin collection will take place biweekly, on the alternate week of recycling collection. Green Bin collection will take place on Wednesdays.

Organic Composting Program

Residential properties will be provided with their first Green Bin for FREE, however if a residential property wants an additional or replacement Green Bin, they can acquire one, by pick-up at the Township office for a price of \$20. The Township will deliver green bins to residents with vehicles that are too small to transport the bins, within a two week period of the residents requesting them, in an effort to coordinate multiple deliveries at once to find efficiencies. It should be noted that residents with multiple green bins will also be charged multiple special area rates; each green bin is charged the special area rate individually (i.e. it is a per bin rate vs per property).

On a monthly basis at the beginning of each month, municipal staff will generate a report of occupancy permits granted for new residential dwellings in the Talbotville Settlement Area and arrange for delivery of Green Bins to recently occupied new homes. Residents who want their Green Bin before the monthly delivery can attend the municipal office and pickup their bin ahead of time.

Residents are not able to "opt out" of the Green Bin program. Whether they use the program or not, the special area rate is applied to the final tax bill.

Special Area Rate for Talbotville Settlement Area:

With the introduction of an organic collection program for the Talbotville Land Use area, the residents in this area will be charged a special area rate, given that they benefit from an additional service level. For 2024, this special area rate will be: \$70.84/year

While area rating can be a set amount per property or based on other items like property assessment, frontage, etc. Based on the nature of this program a set amount per household is the most logical.

The special area rate will be added to the final tax bill for each property. The 2024 rate will be prorated for 8 months vs. the entire year, since the program is starting in May.



Council Highlights

**Tuesday,
April 9, 2024**

In This Issue:

Mapping Progress: The Evolution of Elgin County's GIS Platform

Preserving the Past, Engaging the Present: Service Updates from Elgin County's Library, Museum, and Archives

Bridge Rehabilitation: Awarding Engineering Services Contract to Spriet Associates London Limited

Revitalizing County Roads: Contracts Awarded for Asphalt Recycling and Paving Projects

Mapping Progress: The Evolution of Elgin County's GIS Platform

Elgin County has witnessed the evolution of its Geographic Information System (GIS), the "Elgin GeoHub," since its establishment in 2021. Over the past three years, all of Elgin's municipalities have transitioned, or plan to transition, their GIS services to the County's server, marking a significant milestone in regional collaboration. With 65 municipal employees and approximately 15,000 public users accessing the system, the GeoHub has become a vital resource for municipal operations and public engagement. To formalize the provision of GIS services, a shared service agreement has been prepared, outlining base services provided by the County and mechanisms for requesting additional project work. With an approximate annual cost of \$90,000 for software licenses and suites, excluding consulting and maintenance costs, Elgin County remains committed to supporting its municipal partners' evolving needs through GIS technology. Council authorized the Warden and Chief Administrative Officer to execute the Geographic Information System shared service agreement with Elgin's local municipal partners, furthering the County's dedication to fostering regional collaboration and innovation. Members of the public are encouraged to visit the County's GIS platform online by visiting <https://geohub.elgin.ca/>.

Preserving the Past, Engaging the Present: Service Updates from Elgin County's Library, Museum, and Archives

Elgin County Council received a report from the Director of Community and Cultural Services offering a comprehensive service update for Elgin County's Library, Museum, and Archives. This update detailed recent programs, projects, and initiatives undertaken by each institution. The following highlights include the noteworthy achievements and activities across these cherished cultural institutions.

Elgin County Library:

- Implemented a novel postcard registration system to ensure individuals facing housing insecurity could access library services, reflecting the library's commitment to diversity and inclusion.
- Hosted a variety of engaging March Break activities across all branches, including reptile shows, ventriloquism acts, and craft workshops, attracting high attendance and fostering community engagement.
- Offered educational programming centered around the total solar eclipse, providing residents with opportunities to learn about and observe the celestial event at multiple library branches.



Ray's Reptiles program at the Shedden Library branch welcomed over 250 enthusiastic children and parents during March Break

Preserving the Past, Engaging the Present: Service Updates from Elgin County's Library, Museum, and Archives Continued

Elgin County Museum:

- Presented a captivating talk by former Warden Paul Baldwin on the musical legacy of harmonica virtuoso Tommy Riley and his father James, drawing an audience of history enthusiasts and garnering significant media attention.
- Showcased the exhibit 'Port Stanley – Canada's Coney Island,' which explored the village's rich entertainment history, including amusement rides and beach attractions, as part of Bicentennial celebrations.
- Completed an interpretive mural depicting the settlement journey of the Oneida Nation of the Thames, created by volunteers from the Oneida Language & Cultural Centre, furthering cultural understanding and promoting inclusivity.
- Welcomed Madeleine Howard as the new Curator, succeeding the retiring Mike Baker, and celebrated Mike's distinguished career with a special event at the Heritage Centre, honoring his contributions to preserving Elgin County's heritage.



Paul Baldwin delivers a presentation on the musical legacy of harmonica virtuoso Tommy Riley at the Elgin County Heritage Centre

Preserving the Past, Engaging the Present: Service Updates from Elgin County's Library, Museum, and Archives Continued

Elgin County Archives:

- Made significant progress in digitizing historical newspapers, scanning over 87,000 pages, which included coverage of the First World War and Interwar period, providing valuable insights into the County's past.
- Expanded social media presence, reaching millions of people and generating interest in Elgin County's history through captivating photographs, behind-the-scenes glimpses, and engaging content. The most popular Elgin County photograph on Facebook for the past year was the exterior of Mackie's/Port Stanley boardwalk, circa 1947. That post reached over 110,000 people and was interacted with just over 7,000 times.
- Conducted outreach initiatives, such as green screen programs at local markets and educational presentations at schools, to connect with the community and promote historical awareness and appreciation.



Photograph showing the exterior of Mackie's in Port Stanley, circa 1947

Bridge Rehabilitation: Awarding Engineering Services Contract to Spriet Associates London Limited

Council received a report from the Director of Engineering Services respecting the required engineering services for multiple bridge rehabilitations, including the Eden Bridge, Gillets Bridge, Mapleton Bridge, Players Bridge, and Port Burwell Bridge. The two-year project comprises Phase 1, encompassing engineering designs, tender, permits, and approvals in 2024, and Phase 2, involving construction inspection and contract administration in 2025. Following a rigorous evaluation process, Spriet Associates London Limited emerged as the highest scoring qualified proposal, representing the best complete submission. The total cost for engineering services, construction inspection, and contract administration is \$279,900, with sufficient funding allocated in the 2024 and proposed 2025 capital budgets. Council directed and authorized the Warden and Chief Administrative Officer to sign the contract with Spriet Associates London Limited for the amount of \$279,900.

Revitalizing County Roads: Contracts Awarded for Asphalt Recycling and Paving Projects

In alignment with the 2024 Capital Budget, tenders were issued for Cold In-Place Asphalt Recycling and Hot Mix Asphalt Paving on various County roads. Council authorized the Warden and Chief Administrative Officer to sign the contracts, marking a significant step towards road improvement. For Cold In-Place Asphalt Recycling, Roto-Mill Inc. was selected for the rehabilitation of seven County roads. Utilizing a Cold In-Place Asphalt Recycling with Expanded Asphalt Material (CIREAM) technique, these projects aim to enhance road conditions effectively. Similarly, Brantco Construction secured the Hot Mix Asphalt Paving contract for eleven road projects, ensuring quality resurfacing and granular shoulder installations. The total cost for Cold In-Place Asphalt Recycling amounts to \$2,628,071.93, while Hot Mix Asphalt Paving totals \$4,567,904.30. Anticipated budget surpluses reflect efficient financial planning, ensuring project completion within allocated funds despite potential fluctuations in material costs. With contracts awarded, work on these vital road projects is slated to commence in May, with completion targeted by September 2024. Adherence to the County's Purchasing Policy ensures transparent financial management, with provisions for change orders outlined to address unforeseen circumstances.

For the complete April 9, 2024 Agenda Package, please visit the following link:
[County Council Agenda Package](#)

Hi June,

Below is the request to Council asking for a letter of support for the baseball tournaments. Her 16 dates booked at the Fingal Ball Park are as follows:

May 4th
May 11th
May 25th
June 1st
June 15th
June 22nd
July 13th
July 20th
Aug 3rd
Aug 10th
Aug 17th
Aug 24th
Sept 14th
Oct 5th
Oct 19th
Oct 26th

Thanks,

Brittany Jessome
Community Services & Communications Clerk

email communications@southwold.ca
tel 519-769-2010

Township of Southwold
35663 Fingal Line, Fingal, Ontario, N0L 1K0

The contents of this e-mail and any attachments are intended for the named recipient(s). This e-mail may contain information that is privileged, confidential and/or exempt from disclosure under applicable law. If you have received this message in error, are not the named recipient(s), or believe that you are not the intended recipient immediately notify the sender and permanently delete this message without reviewing, copying, forwarding, disclosing, or

otherwise using it or any part of it in any form whatsoever.

-----Original Message-----

From: Lauri Whitbourn

Sent: Friday, April 12, 2024 1:22 PM

To: Brittany Jessome <communications@southwold.ca>

Subject: letter to board

Subject: Proposal for a Bar at the Baseball Tournament

Dear Members of the Town Council,

I hope this letter finds you well. As an avid supporter of community events and someone deeply invested in the success of my baseball tournaments, I am writing to express my strong belief that including a bar at the upcoming baseball tournament would greatly enhance the overall experience for both participants and spectators alike.

Here are a few reasons why I believe a bar would be a valuable addition to the event:

1. **Social Gathering:** Baseball tournaments are not just about the games themselves; they are also about fostering a sense of community and providing opportunities for people to come together and socialize. Having a bar on-site would create a designated space where attendees can mingle, connect, and share in the excitement of the tournament.

2. **Enhanced Enjoyment:** Enjoying a refreshing beverage while watching a baseball game is a cherished pastime for many. By offering a selection of beverages at the tournament, I can enhance the enjoyment of the event for attendees and provide them with a more complete experience.

3. **Revenue Generation:** Introducing a bar at the baseball tournament has the potential to generate additional revenue for the town. Proceeds from beverage sales could be reinvested into community initiatives or used to support future events, ultimately benefiting the entire town. I am also going to contact the Optimist club to see if they would like to run a few dates so they can make a little revenue as well.

4. **Responsible Service:** It's important to emphasize that any alcohol service at the tournament

would be conducted responsibly, with appropriate measures in place to ensure the safety and well-being of all attendees. I can work closely with licensed bartenders to implement strict age verification processes and promote responsible drinking practices.

In conclusion, I believe that incorporating a bar into the baseball tournament would not only enhance the event experience but also contribute positively to your community. I kindly request that the Town Council consider this proposal and explore the possibility of making it a reality for my upcoming tournaments throughout the season.

Thank you for your time and consideration.

Sincerely,
Lauri Whitbourn

April 24, 2024

To our Municipal clients:

Re: Assessment of Bill 185, *Cutting Red Tape to Build More Homes Act, 2024* and the Proposed Provincial Planning Statement, 2024

On behalf of our many municipal clients, we are writing to inform you of the Ontario Legislature's proposed changes to the *Planning Act* under Bill 185 (*Cutting Red Tape to Build More Homes Act*) and the proposed Provincial Planning Statement, 2024 (PPS, 2024). The primary focus of this letter is to provide our assessment of the proposed PPS, 2024 and its potential impacts on growth management in Ontario. The proposed PPS, 2024 was released in coordination with Bill 185 on April 10, 2024, for a 30-day comment period. The comment period on the proposed PPS, 2024 ends on May 12, 2024 (the deadline was extended by two days after the release of the French version of the proposed PPS, 2024). The PPS is provided under section 3 of the *Planning Act* and if the proposed PPS, 2024 is approved, all municipal decisions would be required to be consistent with the PPS, 2024 under subsections 3 (5) and 3 (6) of the *Planning Act*.

1. Proposed Planning Act Changes

With respect to the proposed changes to the *Planning Act* under Bill 185, we have identified the following key impacts as they broadly relate to growth management in Ontario.

Upper-Tier Municipalities with No Planning Responsibilities to Come into Effect on July 1, 2024, for the Regional Municipalities of Halton, Peel, and York

- The Province introduced the concepts of “upper-tier municipalities without planning responsibilities” and “upper-tier municipalities with planning responsibilities” to the *Planning Act* as part of Bill 23. “Upper-tier municipalities without planning responsibilities” includes a list of seven upper-tier municipalities comprising all the upper-tier municipalities in the Greater Toronto Area, as well as the County of Simcoe, the Region of Niagara, and the Region of Waterloo. Bill 185 builds upon this and amends the *Planning Act* to implement changes to certain upper-tier municipalities, “upper-tier municipalities without planning responsibilities.”
- Under Bill 185, the Region of Halton, the Region of Peel, and the Region of York will become “upper-tier municipalities without planning responsibilities” on July 1, 2024. The County of Simcoe, the Region of Durham, the Region of Niagara, and the Region of Waterloo will become “upper-tier municipalities without planning



responsibilities” at a future date to be named by proclamation of the Lieutenant Governor.^[1]

- Upon the review of Bill 23, Watson & Associates Economists Ltd. (Watson) previously expressed concerns with these significant changes to regional planning. We anticipate that there will continue to be a strong need for impacted upper-tier municipalities to address regional growth management coordination efforts (e.g., coordination of regional growth forecasts and regional urban land needs assessments, assessment of regional infrastructure needs and review of cross-jurisdictional issues) working with their area municipalities.

Elimination of Third-Party Appeal Rights to Include Municipally Approved Official Plans, Official Plan Amendments, Zoning By-Laws and Zoning By-Law Amendments

- As part of Bill 23, the Province amended the *Planning Act* to limit appeals for minor variances, a plan of subdivision, or a consent to sever to the applicant, the municipal authority, the Minister, or a “specified person.” “Specified person” is a new term introduced with the intent to focus appeals on a more focused group, including applicants, public bodies, Indigenous communities, and utilities providers. Appeal rights removed include third-party landowners, ratepayers, and other members of the public that are not the applicant, the Minister, an approval authority, a public body, or a “specified person.” Under Bill 185, it is proposed that the elimination of third-party appeals would be extended to include municipally approved Official Plans, Official Plan Amendments, Zoning By-laws and Zoning By-law Amendments.^[2]
- Bill 185 proposes to remove appeal rights for “upper-tier municipalities with no planning responsibilities”; these upper-tier municipalities will only be able to provide comments on applications. As a result, utility providers will have stronger tools (including appeal rights) to protect their infrastructure relative to upper-tier municipalities who are responsible for managing and building infrastructure, as well as the associated risks (e.g., financial and public safety).^[3]

Restore Appeal Rights for Privately Initiated Settlement Area Boundary Expansions

- Private-sector applications for a boundary of area of settlement (settlement area expansions) can be appealed to the Ontario Land Tribunal (OLT) provided that it

^[1] Bill 185, Schedule 1, section 1.

^[2] Bill 185, Schedule 12, section 3 (1).

^[3] The Regional Municipality of York, Report of the Commissioner of Corporate Services and Chief Planner for Regional Council on April 25, 2024 – Cutting Red Tape to Build More Homes Act, 2024 (Bill 185) – Proposed Changes to Planning Act, 1990, Municipal Act, 2001 and Provincial Planning Statement.



is not within the Greenbelt Area. Under the current *Planning Act*, an applicant cannot appeal an Official Plan Amendment or Zoning By-law Amendment application that would expand or alter an in-force settlement area boundary.^[1] It is important to note that this appeal right does not extend to settlement boundary expansions that have received a Minister's decision as part of an Official Plan and Official Plan Amendment. The Minister's decision is still final.

- Permitting appeals may result in more land being designated through OLT decisions than what was identified by municipalities in Official Plans and would potentially have the impact of undermining local growth management objectives established through an Official Plan Review.

A New “Use it or Lose it” Tool for Municipalities to Tackle Stalled Developments

- Proposed changes to the *Planning Act* include a new “use it or lose it” tool for municipalities to tackle stalled developments that have unused servicing capacity allocation (water and sewage servicing). The proposal as part of Bill 185, includes a framework for the municipality to expand the scope of lapsing provisions, including requiring approval authorities to impose a lapsing condition for all draft subdivision/condominium and site plan control approvals.^[2] Previously, this was an option for municipalities; now it is a requirement. It should be noted that municipalities can provide for lapsing provisions of previous applications, subject to notice to the owner.^[3]
- The new provisions would provide an incentive for developers/builders to move forward on an approved application. From a growth management perspective, this tool would potentially provide more certainty when determining housing and land supply potential to accommodate growth within the short term.

Create a New “Servicing Management” Tool to Facilitate Infrastructure Servicing Re-Allocation to Make More Efficient Use of Municipal Servicing Capacity

- This bill proposes to create a new municipal servicing management tool that would explicitly authorize municipalities to adopt policies by by-law (if they do not already exist) to establish how water and sewage servicing of an approved development is managed. Furthermore, it would enable municipalities to allocate and reallocate servicing capacity to other projects if the approved development has not proceeded after a specified timeline and the servicing is needed elsewhere in the service area. Should municipalities adopt such a by-law, it would not be appealable to the OLT.^[4]

^[1] Bill 185, Schedule 12, section 6 (4).

^[2] Bill 185, Schedule 12, section 10 (3) and section 12.

^[3] Bill 185, Schedule 4, section 2.

^[4] Bill 185, Schedule 12, section 14.



- Currently, the *Planning Act* already provides municipalities with the authority to enact by-laws to establish an allocation system for water and wastewater servicing for lands that are subject to a draft plan of subdivision. Bill 185 proposes to repeal this provision of the *Planning Act* and give municipalities the authority to pass by-laws to create a policy for water and servicing capacity, which may include the tracking of water and wastewater servicing capacity for approved developments and establishing criteria for the allocation to future development applications.^[1] Bill 185 proposes to replace this policy in the *Planning Act* and to add a new section 86.1 to Part III (Specific Municipal Powers) of the *Municipal Act, 2001*.^[2]
- These changes will empower municipalities to shift servicing allocation that will deliver the development of homes and employment growth opportunities faster. Furthermore, it provides more transparency on the expectations of servicing for future development applications.

Elimination of Parking Standards in Protected Major Transit Station Areas to Provide More Flexibility

- Proposed changes to the *Planning Act* will include prohibiting municipalities from setting parking minimums in Protected Major Transit Station Areas (PMTSAs). This would allow the market and developers the ability to decide the parking requirements in PMTSAs based on market needs.^[3] This could provide opportunities to increase housing yields in PMTSAs and possibly reduce development costs through potentially lower parking requirements.

A New Minister's Zoning Orders (MZO) Framework

- To provide better transparency at the provincial level, the Province has established a framework setting out how requests for zoning orders will be received and considered. The framework includes intake thresholds, submission requirements, and a process for Ministry assessment and decision-making. The intake requirements would need to demonstrate that the MZO delivers on a provincial priority that is supported by an Ontario government ministry and/or is supported by a single-tier or lower-tier municipality through a municipal council resolution or a letter from a mayor with strong mayor powers. Formal input from upper-tier municipal councils is excluded from the intake requirements. Submission requirements that should be provided with an application include a rationale on why the project requires ministerial zoning relief rather than following

^[1] Based on interpretation by McMillan LLP, Introducing Bill 185, the Cutting Red Tape to Build More Homes Act, and an Update on the New Provincial Planning Statement, April 17, 2024.

^[2] Bill 185, Schedule 9 (*Municipal Act, 2001*).

^[3] Bill 185, Schedule 12, section 2.



municipal planning processes; a description of consultation with the public and engagement with Indigenous communities; and information related to how and when servicing (water/wastewater) will be addressed.^[1]

- While the applicant is required to demonstrate that it supports provincial priorities and/or local council support, the MZO framework does not require an applicant to support the need for the application in consideration of existing urban land supply opportunities, the status of other applications within municipalities, or forecast demand for housing within an established planning horizon. Provincial priorities established in the framework are very broad and include addressing housing and economic development opportunities which would not limit many applications, if any.
- We continue to support the recommendations provided to the Province by the Association of Municipalities of Ontario to improve the MZO framework that would include MZOs being used in collaboration with municipalities and use MZOs only in situations of extraordinary urgency.^[2]

Remove the Community Infrastructure and Housing Accelerator Tool from the *Planning Act*

- The proposed changes would include removing the Community Infrastructure and Housing Accelerator (CHIA) tool (brought in under Bill 109) from the *Planning Act*.^[3] Instead of the CHIA tool, municipalities can rely on the new MZO framework that provides clarity on how MZO requests from municipalities will be received and considered going forward.
- Proposed transition rules will be provided to permit CHIA orders that have been made to date to continue functioning as municipal zoning by-laws.

Enhance and Expand Municipal Planning Data Regulation (O. Reg. 73/23) to Include 21 Additional Municipalities (50 Municipalities in Total)

- On April 6, 2023, Ontario Regulation (O. Reg.) 73/23: Municipal Planning Data Reporting (as part of Bill 109), came into effect. This regulation requires 29 municipalities in Ontario to report information on planning matters to the Ministry on a quarterly and annual basis. The 29 municipalities have already provided reporting on a quarterly basis. Under Bill 185, this would be expanded to 50 municipalities.^[4]

^[1] Province of Ontario – Zoning Order Framework, retrieved online: [Zoning order framework | ontario.ca](#), accessed April 19, 2024.

^[2] Association of Municipalities of Ontario, retrieved online: [Bill 185, Cutting Red Tape to Build More Homes Act, 2024 | AMO](#), accessed April 19, 2024.

^[3] *Planning Act*, section, 34.1.

^[4] Environmental Registry of Ontario, ERO 019-8368, Proposed Amendments to Ontario Regulation 73/23: Municipal Planning Data Reporting.



- The reporting requirements include preparing a standardized summary table that outlines key statistics on planning applications for each quarterly report (e.g., total number of submissions, decisions) and documenting changes to settlement area boundaries, Employment Area conversions, and major transit station areas (MTSAs) on an annual basis. Providing geospatial data that identifies designated serviced land supply is also required as part of the reporting. The additional 21 municipalities would be required to publish this summary on their respective municipal webpages and update the summary each quarter, beginning October 1, 2024.^[1]
- It is our opinion that this regulation change is a key step forward in setting minimum standards for municipalities in reporting land supply. This also provides an opportunity for the municipalities to build upon these provincial requirements and proactively track and monitor growth, which will better empower municipalities in making informed decisions on planning for growth.

Enhancing and Broadening the Framework for Additional Residential Units

- Under subsection 35.1 (2) of the *Planning Act*, the Minister is authorized to make regulations regarding Additional Residential Units (ARUs) by establishing requirements and standards with respect to a second or third residential unit in a detached house, semi-detached house, or rowhouse, as well as a residential unit in a building or structure ancillary to such a house.
- Bill 185 proposes to broaden provisions to allow the Minister to regulate any ARUs in an existing home (as noted above) or ancillary structure for the purposes of an ARU. If approved, the Minister will have a new regulation-making power to remove zoning barriers to accommodate ARU developments which may include maximum lot coverage and limits on the number of bedrooms allowed per lot.^[2]

2. Proposed Provincial Planning Statement, 2024

In 2023, the Province set in motion consultation on a Provincial Planning Statement (PPS, 2023) that proposes to integrate the Provincial Policy Statement, 2020 (PPS, 2020) and A Place to Grow: Growth Plan for the Greater Golden Horseshoe (Growth Plan) into a single document. The proposed PPS, 2023 was released for public comment in April 2023 and was introduced as part of Bill 97 – *the Helping Homebuyers, Protecting Tenants Act*. On April 10, 2024, the Province posted another draft of the PPS. Based on a review by Watson, we note that the PPS, 2024 is not significantly different than the previous PPS, 2023. There are, however, more parameters, additional guidance, and strengthening of policies related to the management of growth

^[1] Ontario Regulation 73/23 filed April 6, 2023, under *Planning Act*, R.S.O. 1990, c. P.13.

^[2] Bill 185, Schedule 12, section 9.



relative to the proposed PPS, 2023. Provided below are key highlights of the proposed PPS, 2024 with a key focus on growth management in Ontario. Some of the highlights below include policies that are proposed to be carried forward from the PPS, 2023.

A Flexible Growth Forecast Horizon

Compared to the PPS, 2020, the proposed PPS, 2024 provides a more flexible horizon for planning for growth by providing a planning horizon with a minimum of 20 years and a maximum of 30 years. Similar to the proposed PPS, 2023, “planning for infrastructure, public service facilities, strategic growth areas and employment areas may extend beyond this time horizon.”^[1] Based on our interpretation of the proposed PPS, 2024, this would suggest that municipalities are to designate land to accommodate growth over a 20- or 30-year period, with the opportunity to designate additional land beyond the 30-year time horizon for Employment Areas.

Initial Direction on Growth Forecasting

The proposed PPS, 2024 notes that “planning authorities shall base population and employment growth forecasts on Ministry of Finance (MOF) 25-year projections and may modify projections, as appropriate”^[2] (underlining added). It is our interpretation that municipalities are not required to utilize the MOF forecasts and that they are not meant to replace long-term forecasting by municipalities. It is important to note that the MOF population forecasts are provided at the Census division level only, which typically represents upper-tier municipalities, including separated municipalities (e.g., the City of Stratford and the Town of St. Marys are included with the County of Perth Census Division) and large urban single-tier municipalities. The MOF does not provide forecasts at the area municipal level.^[3] Furthermore, the most recent Summer 2023 MOF forecast provides growth estimates to the year 2046. Subsection 2.1.3 of the proposed PPS, 2024 states that urban land needs can be calculated up to 30 years. As such, current MOF forecasts would need to be extended from 2046 to 2054 to accommodate a full 30-year planning horizon. It is our interpretation that the use of the MOF forecasts is not meant to replace long-term forecasting by municipalities but the forecasts are to be used as a starting place in establishing forecasts and testing the reasonableness of alternative regional forecasts and area municipal growth allocations, a practice that Watson currently carries out.

Municipalities within the Greater Golden Horseshoe (GGH) are required to continue to use forecasts issued by the Province through Schedule 3 of the Growth Plan until more

[1] Proposed PPS, 2024, policy 2.1.3, p. 6

[2] Proposed PPS, 2024, policy 2.1.1, p. 6

[3] Census division is the general term for provincially legislated areas (such as municipality, county, region or district) or their equivalents. Census divisions are intermediate geographic areas between the province/territory level and the municipality (Census subdivision).



current forecasts are available to 2051, as informed by guidance provided by the Province.^[2] Forecasts established in Schedule 3 of the Growth Plan and the allocation of growth by lower-tier municipality are to be considered minimum growth forecasts. It is unknown at this time whether this policy of growth forecasts as minimums will be carried forward. We anticipate that future guidance documents will provide direction on this matter.

It should be noted that the proposed PPS, 2024 encourages growth management undertaken by municipalities to be coordinated with adjacent planning authorities when planning is not conducted by an upper-tier municipality.^[3] We envision the need for local municipalities, where planning is not conducted by an upper-tier municipality, to include a consultation process or technical advisory group comprising representatives of adjacent municipalities when conducting Official Plan Reviews and other related comprehensive planning studies.

Minster's Zoning Orders (MZOs) are Considered in Addition to Projected Needs

According to the proposed PPS, 2024, MZOs are to be treated as “in addition to projected needs” over the planning horizon. In planning for MZO lands, the proposed PPS, 2024 states these lands must be incorporated into the Official Plan and related infrastructure plans.^[4] Since MZO lands are not tied to an assessment of need, it is recommended that when planning for these lands the timing of their buildout is not held to a targeted minimum or maximum planning horizon. As such, it is recognized that full development of MZOs may or may not extend beyond the 30-year maximum planning horizon set out in the proposed PPS, 2024, subject to anticipated economic growth and real estate market demand within the municipality and the broader economic region over the horizon of the plan. It is our opinion that the timing of development regarding approved MZOs should be established through provincial and local phasing policies, municipal servicing plans, and reviewed through regular monitoring.

Providing for an Appropriate Range and Mix of Housing Options

Similar to the proposed PPS, 2023, under subsection 2.1.4 of the proposed PPS, 2024 planning authorities are to:

- a) maintain at all times the ability to accommodate residential growth for a minimum of 15 years through lands which are designated and available for residential development; and

^[2] Proposed PPS, 2024, policy 2.1, p. 6; and Environmental Registry of Ontario, ERO 019-8462: Review of proposed policies for a new provincial planning policy instrument.

^[3] Proposed PPS, 2024, policy 6.2.10, p. 36.

^[4] Proposed PPS, 2024, policy 2.1.1, p. 6.



- b) maintain at all times where new development is to occur, land with servicing capacity to provide at least a three-year supply of residential units available through lands suitably zoned, including units in draft approved registered plans.

We recommend that where planning authorities have established minimum targets for intensification and redevelopment, these targets are considered in the assessment of proposed PPS, 2024 policy 2.1.4. a) and b).

Subsection 2.1.5 of the proposed PPS, 2024 identifies that where planning is conducted by an upper-tier municipality, the land and unit supply maintained by the lower-tier municipality shall be based on and reflect the allocation of population and units by the upper-tier municipality. This policy emphasizes the need for urban land and housing needs to be assessed at the local municipal level within two-tier planning systems.

Anticipated Guidance Documents on Growth Forecasting and Land Needs

We anticipate that the Province will release a guidance document on projecting growth and associated land requirements.^[5] On March 12, 2024, the Province re-opened a proposal on Environmental Registry Ontario (ERO) for A Proposed Approach to Update the Projection Methodology Guideline.^[6] This proposal was initially posted in June 2021 following the release of the PPS, 2020. As noted in the ERO proposal summary, the last provincial guidance document on growth projections and land needs for the entire Province was provided in 1995. The 1995 Projection Methodology has been generally used by Watson as a source of best practice for growth forecasting. Since 1995, the Province released a Land Needs Assessment Methodology for the GGH with a few updates.^[7] This document has since been used as a best practice for projecting growth and urban land needs across the GGH.

It should be noted that the Province has not yet updated the document entitled, “Proposed Approach to Implementation of the Proposed Provincial Planning Statement” which accompanied the proposed PPS, 2023 in April 2023.

^[5] The ERO 019-2346 proposal summary notes that “Guidance for projecting population and related land requirements may be updated after finalization of the proposed Provincial Planning Statement to reflect final policy direction and considering feedback received.”

^[6] Environmental Registry of Ontario, ERO 019-2346, A Proposed Approach to Update the Projection Methodology Guideline.

^[7] The last update to the methodology came into effect on August 28, 2020. The proposed PPS plans to combined both the PPS and the Growth Plan and if approved, this document would no longer be in force.



No Significant Policy Change and Approach to Planning for Affordable Housing

The proposed PPS, 2024 carries forward a similar definition of affordable housing as established in the PPS, 2020. The definition of affordable housing in the proposed PPS, 2024, however, is based on the municipality instead of the regional market area as defined in the PPS, 2020. The definition of affordable housing was notably missing in the proposed PPS, 2023. Additionally, the proposed PPS, 2024 carries forward the requirement of “establishing and implementing minimum targets for the provision of housing that is affordable to low- and moderate-income households.”^[9] The proposed PPS, 2024 does not address the issue of attainable housing, an issue that was also lacking in the PPS, 2020.

Settlement Areas Remain Focus of Growth and Development

The proposed PPS, 2024 identifies that settlement areas shall be the focus of growth and development. Within settlement areas, where applicable, growth should be focused in Strategic Growth Areas (SGAs), including Major Transit Station Areas (MTSAs), and that planning authorities shall support general intensification and redevelopment to promote the achievement of complete communities. Planning authorities are encouraged to establish and implement minimum targets for intensification and development within built-up areas, based on local conditions. Planning authorities are also encouraged to establish density targets for designated growth areas, based on local conditions. Large and fast-growing municipalities are encouraged to plan for a target of 50 residents and jobs per gross hectare in designated growth areas. Large and fast-growing municipalities are identified in Schedule 1 of the proposed PPS, 2024.

Based on our experience, all large and fast-growing municipalities are anticipated to achieve average densities in designated growth areas above 50 residents and jobs per gross hectare. Accordingly, it is recommended that this density target is considered a minimum.

Identifying New Settlement Areas and Settlement Area Boundary Expansions

According to the proposed PPS, 2024, Settlement Area Boundary Expansion (SABE) is allowed at any time and without the requirement of a Municipal Comprehensive Review or Comprehensive Review, provided that all PPS policies under subsection 2.3.4 are considered.^[10] Furthermore, the policies allow for a simplified and flexible approach for municipalities to undertake a SABE which would require a demonstrated need for urban expansion. It should be noted that the criteria in the proposed PPS, 2024 has been expanded compared to the proposed PPS, 2023. Additionally, the language has

^[9] Proposed PPS, 2024, policy 2.2.1, p. 7.

^[10] Proposed PPS, 2024, policy 2.3.4, p. 7. Under the A Place to Grow: Growth Plan for the Greater Golden Horseshoe, 2019 and the PPS, 2020, SABEs were permitted only through a Municipal Comprehensive Review.



changed from “should consider” in the proposed PPS, 2023 to “shall consider” in the proposed PPS, 2024. The proposed PPS, 2024 does carry over the concept of demonstrating the need for additional land as identified in the PPS, 2020 which was not included in the proposed PPS, 2023.

While the proposed PPS, 2024 does not require a prescriptive approach to determining the need for expansion as provided in the Growth Plan or the PPS, 2020, it does require municipalities to consider infrastructure needs and the phased progression of growth. Furthermore, for new settlement areas, the proposed PPS, 2024 adds a stand-alone policy requiring municipalities to demonstrate that the infrastructure and public service facilities are planned or available for new settlement areas.^[11]

We recommend that a policy is added to subsection 2.3.2.1 of the proposed PPS 2024 that identifies where planning authorities have established minimum targets for intensification and redevelopment within built-up areas and that implementation of these targets shall be considered prior to identifying the need for new settlement areas.

Planning for Growth in Major Transit Station Areas

Under the proposed PPS, 2024, intensification policies have become less prescriptive compared to the PPS, 2020, with a focus on encouraging rather than setting out requirements. As previously noted, according to the proposed PPS, 2024, planning authorities are encouraged (rather than required) to establish minimum targets for intensification and redevelopment within their respective built-up areas. Targets for intensification are encouraged in MTSA's and all municipalities (i.e., not just large and fast-growing municipalities as identified in the proposed PPS, 2023) shall plan to meet minimum density targets.^[12] Minimum density targets for MTSA's are based on the transit service level:

- a) 200 residents and jobs combined per hectare for those that are served by subways;
- b) 160 residents and jobs combined per hectare for those that are served by light rail or bus rapid transit; or
- c) 150 residents and jobs combined per hectare for those that are served by commuter or regional rail.^[13]

[11] Proposed PPS, 2024, policy 2.3.2, p. 8.

[12] Proposed PPS, 2024, policy 2.2.3.1.4, p. 8

[13] Proposed PPS, 2024, policy 2.2.3.1.4, p. 8



Expanded Scope of Strategic Growth Areas, but No Targets on Density

The proposed PPS, 2024 carries over the concept of SGAs from the proposed PPS, 2023. The concept of SGAs was initially introduced in the Growth Plan. According to the proposed PPS, 2024, SGAs include:

major transit station areas, existing and emerging downtowns, lands adjacent to publicly assisted post-secondary institutions and other areas where growth or development will be focused, that may include infill, redevelopment (e.g., underutilized shopping malls and plazas), brownfield sites, the expansion or conversion of existing buildings, or greyfields. Lands along major roads, arterials, or other areas with existing or planned frequent transit service or higher order transit corridors may also be identified as strategic growth areas.^[14]

The proposed PPS, 2024 expands on the description of SGAs to include a greater range of site areas focused for infill and redevelopment, such as underutilized shopping malls and plazas, suggesting that SGAs may include a range of site sizes, with an expanded focus on non-residential sites. It is important to note that, unlike the proposed PPS, 2023, the proposed PPS, 2024 encourages all municipalities (i.e., not just the large and fast-growing municipalities) to focus growth and development in SGAs to achieve higher density outcomes.

Other than minimum density targets for MTSAs, minimum density targets for other SGAs have not been carried forward from the proposed PPS, 2023 and the Growth Plan. Furthermore, Urban Growth Centres, a component of SGAs set out in the proposed PPS, 2023 and the Growth Plan, have not been carried forward in the proposed PPS, 2024. Instead, the proposed PPS, 2024 provides more simplified direction to plan for downtowns as SGAs.

A Narrow Definition of Employment Area

The proposed PPS, 2024 includes an updated definition of Employment Area based on the amendment of the *Planning Act* on June 8, 2023. The *Planning Act* was amended under subsection 1 (1) to include a new definition of “area of employment.” The amendment to the *Planning Act* received Royal Assent as part of Bill 97 on June 8, 2023. The definition change in the *Planning Act* would require proclamation before it becomes in effect.

Under the new definition of Employment Area, municipalities are required to plan for, and protect, industrial uses based on a more narrowly scoped definition of Employment Area and are limited to these uses that are primarily industrial in nature or other uses associated or ancillary to the primary use. Employment Area lands and uses that do not

^[14] Proposed PPS, 2024, definitions, p. 53.



meet the definition of Employment Area should be removed from Employment Areas. Lands that do not meet the Employment Area definition would not be subject to provincial Employment Area protection policies and would allow for opportunities for residential and other non-employment uses.^[15]

In light of the definition change of Employment Area, a key concern for municipalities will be their ability to provide an urban structure that will support employment uses outside of Employment Areas, particularly non-retail commercial and institutional uses (e.g. office uses, training and education, entertainment, wholesale trade and service repair centres). Traditionally, Employment Areas have been regarded as areas protected for key targeted employment sectors, especially those in the export-based sectors.

As previously discussed, municipalities are allowed to forecast beyond a 30-year period for Employment Areas.^[16] Furthermore, it should be noted that the Provincially Significant Employment Zones identified in the Growth Plan are not proposed to be carried forward. The Province has suggested in the PPS, 2024 proposal summary that the policies in the PPS are sufficient for protection for Employment Areas.^[17]

Unlocking Residential Opportunities on Non-Residential Lands and Supporting Mixed-Uses

The proposed PPS, 2024 requires that municipalities unlock more opportunities for housing, stating that municipalities should support redevelopment of commercially designated retail lands (e.g., underutilized shopping malls and plazas) to support mixed-use residential.^[18] Furthermore, the proposed PPS, 2024 notes that Employment Areas that do not meet the definition of Employment Area, referred to as “employment outside of Employment Areas” should support a diverse mix of land uses, including residential uses.^[19] These lands generally would include office business parks, commercial and institutional lands, and employment lands that do not meet the definition of Employment Area. It is also suggested that specific industrial, manufacturing, and small-scale warehousing uses that do not require separation from sensitive land uses are to be encouraged to locate in mixed-use areas or SGAs where frequent transit service is available, outside of Employment Areas.^[20] Again, under the proposed policy framework, municipalities are anticipated to face greater long-term challenges regarding their ability to strike a balance in accommodating mixed-use development and ensuring an adequate supply of non-residential lands to support employment uses outside of

[15] Proposed PPS, 2024, definitions, p. 34.

[16] Proposed PPS, 2024, policy 2.1.3, p. 6.

[17] Environmental Registry of Ontario, ERO 019-8462, Review of Proposed Policies for a New Provincial Planning Policy Instrument, Proposal Summary, Section 2.

[18] Proposed PPS, 2024, policy 2.4.1.3, p. 9.

[19] Proposed PPS, 2024, policy 2.8.1.3, p. 13.

[20] Proposed PPS, 2024, policy 2.1.8.2, p. 11.



Employment Areas, especially with increasing market pressure to accommodate residential development.

Employment Area Conversions Referred to as Removals of Employment Areas

The proposed PPS, 2024 carries forward similar policies on conversions provided in the proposed PPS, 2023. Under the proposed PPS, 2024, municipalities are provided with greater control over Employment Area conversions (now referred to as Employment Area removals) with the ability to remove lands from Employment Areas at any time. Previously, under the PPS, 2020 and the Growth Plan, municipalities were required to review changes to designated Employment Areas during a Municipal Comprehensive Review or Comprehensive Review. Under the proposed PPS, 2024, municipalities are required to demonstrate that there is an identified need for the removal and the land is not required for Employment Area uses over the long term. Furthermore, the Employment Area removal requires consideration of the impact of the produced use on the function of the Employment Area and whether existing infrastructure and public facilities can accommodate the proposed use.^[23]

It is important to recognize that the definition change may result in already developed Employment Area lands not meeting the definition. Based on the proposed PPS, 2024 emphasis on supporting mixed uses, going forward, municipalities will need to assess whether existing Employment Areas meet the new provincial definition and identify areas that should transition into mixed-use areas. While municipalities are required to plan Employment Areas according to the new definition, existing uses that were legally established prior to the *Helping Homebuyers, Protecting Tenants Act, 2023* came into force are allowed the continuation of use, regardless of whether the use meets the definition change.^[24]

Planning for Growth in the Rural Area Directed to Rural Settlement Areas

Compared to the PPS, 2020, the proposed PPS, 2024 does not significantly change the direction of growth within rural areas. As noted in the proposed PPS, 2024, in rural areas, rural settlement areas “shall be the focus of growth and development and their vitality and regeneration shall be promoted.”^[28] A key update in the proposed PPS, 2024 includes permitting more housing on farms to support farmers, farm families, and farm workers without creating new lots (enhanced policy and criteria supporting additional units).^[29] Unlike the proposed PPS, 2023, the proposed PPS, 2024 does not carry forth policies that would have permitted lot creation in prime agricultural areas.

^[23] Proposed PPS, 2024, policy 2.8.2.4, p. 12.

^[24] *Planning Act*, Schedule 6, section 1 (2).

^[28] Proposed PPS, 2024, policy 2.5.2, p. 11.

^[29] Environmental Registry of Ontario, ERO 019-8462, Review of Proposed Policies for a New Provincial Planning Policy Instrument, Proposal Summary, section 1.



No New Direction on Planning for Rural Employment Areas

The proposed PPS, 2024 identifies that development within rural areas needs to be assessed within the rural context in terms of the scale of servicing and character.^[30] No further direction is provided with respect to development within existing or new Rural Employment Areas. Under subsection 2.2.9.5 of the Growth Plan, the Province provided a framework for Rural Employment Area expansions. The framework identified that expansion of Employment Areas outside settlement areas on rural lands that were designated for employment uses may only be permitted if necessary to support the immediate needs of existing business and if compatible with the surrounding uses.^[31] The proposed PPS, 2024 does not carry forward this policy. Based on the proposed PPS, 2024, it appears that expansion of Rural Employment Areas in the GGH is no longer subjected to the policies that prohibited the creation of new Employment Areas in the rural areas.

New Emphasis in Planning for Public Service Facilities

The proposed PPS, 2024 includes a new definition of public service facilities and requires a greater emphasis on coordination with public service providers, as well as planning for emergency management services, health care institutions, schools and post-secondary institutions.^[32] It is noted that municipalities can plan beyond a 30-year period for public service facilities.^[33]

Consideration of a Student Housing Strategy

The proposed PPS, 2024 recognizes the importance of planning for a post-secondary population, especially in municipalities with a post-secondary institution. This is the first time that provincial planning policy has acknowledged the need to consider student housing needs. The word “student” is not mentioned at all in the PPS, 2020. The proposed policies in the PPS, 2024 would require municipalities to collaborate with publicly assisted post-secondary institutions on the development of a student housing strategy that includes consideration of off-campus housing targeted to students.^[34]

^[30] Proposed PPS, 2024, policy 2.5.2, p. 10.

^[31] A Place to Grow, Growth Plan for the Greater Golden Horseshoe, Office Consolidation, policy 2.2.9.5, p. 28.

^[32] Proposed PPS, 2024, policy 3.1, p. 16.

^[33] Proposed PPS, 2024, policy 2.1.3, p. 6.

^[34] Proposed PPS, 2024, policy 6.2.6, p. 35.



3. Summary Comments on the Proposed Amendments and the PPS, 2024

Watson will be providing a submission through the ERO on these legislative changes. We will continue to monitor the progress of Bill 185 through the legislature, including any guidance documents on implementation, and will continue to keep our clients informed of any changes. If you have any questions, please do not hesitate to contact us.

Yours very truly,

WATSON & ASSOCIATES ECONOMISTS LTD.

Jamie Cook, MCIP, RPP, PLE, Managing Partner
Andrew Grunda, MBA, CPA, CMA, Principal
Peter Simcisko, BA (Hons), MBE, Managing Partner
Sean-Michael Stephen, MBA, Managing Partner
Daryl Abbs, MBE, PLE, Managing Partner
Jack Ammendolia, BES, PLE, Managing Partner

Drainage By-law Number 2024-23

A by-law to provide for a drainage works in the Township of Southwold
in the County of Elgin.

Whereas the council of the Township of Southwold has procured a
report under section 78 (5) of the *Drainage Act* for the improvement
of the Larson Drain East 2024 drain;

And whereas the report dated 2024/03/27 has been authored by Mike DeVos, Spriet Associates
and the attached report forms part of this by-law;

And whereas the estimated total cost of the drainage work is \$4,770.86 ;

And whereas \$0.00 is the amount to be contributed by the Township
of Southwold for the drainage works;

And whereas (Complete this clause only if other municipalities are being assessed a share of the cost of the project.);

 is being assessed in the of
 is being assessed in the of
 is being assessed in the of
 is being assessed in the of

And whereas the council is of the opinion that drainage of the area is desirable;

Therefore the council of the Township of Southwold
pursuant to the *Drainage Act* enacts as follows:

1. AUTHORIZATION

The attached report is adopted and the drainage works is authorized and shall be completed as specified in the report.

2. BORROWING

The Corporation of the Township of Southwold
may borrow on the credit of the Corporation the amount of being the amount necessary for
the improvement of the drainage works.

This project will NOT be debentured.

6. CITATION

This by-law comes into force on the passing thereof and may be cited as the

" Larson Drain East 2024 _____ by-law".

First reading 2024/04/08

Second reading 2024/04/08

Provisionally adopted this 8 day of April, 2024

Name of Head of Council (Last, First Name) <u>Jones, Grant</u>	Signature <u>Original signed by:</u>
---	---

Name of Clerk (Last, First Name) <u>Higgs, Lisa</u>	Signature <u>Original signed by:</u>
--	---

Third reading 2024-04-29

Enacted this 29th day of April, 2024

Name of Head of Council (Last, First Name) <u>Jones, Grant</u>	Signature
---	-----------

Name of Clerk (Last, First Name) <u>Higgs, Lisa</u>	Signature
--	-----------

I, Lisa Higgs

clerk of the Corporation of the Township of Southwold,

certify that the above by-law was duly passed by the council of the Corporation and is a true copy thereof.

Name of Clerk (Last, First Name) <u>Higgs, Lisa</u>	Signature
--	-----------





THE CORPORATION OF THE TOWNSHIP OF SOUTHWOLD

BY-LAW NO. 2024-25

Being a By-Law to authorize the execution of an agreement between Convertus Canada Ltd. and the Corporation of the Township of Southwold for the processing of organic waste from the Green Bin Program

WHEREAS Section 8 (1) of the Ontario Municipal Act, S.O., 2001, c.25 states that the powers of a municipality shall be interpreted so as to confer broad authority on municipalities to enable them to govern their affairs as they consider appropriate and to enhance their ability to respond to municipal issues;

AND WHEREAS Section 9 states that a municipality has the capability, rights, powers and privileges of a natural person for the purpose of exercising its authority under this or any other Act;

AND WHEREAS the customer is responsible for the collection of organic waste within its jurisdiction;

AND WHEREAS the service provider is engaged in the business of receiving and processing organic waste

AND WHEREAS it is the desire of the Corporation of the Township of Southwold to authorize an agreement with Convertus Canada Ltd. for the processing of organic waste.

NOW THEREFORE THE COUNCIL OF THE CORPORATION OF THE TOWNSHIP OF SOUTHWOLD ENACTS AS FOLLOWS:

1. That the Mayor is authorized to sign on behalf of the Corporation of the Township of Southwold the Organic Waste Processing Agreement attached to this By-law as Schedule "A".
2. This By-law shall come into force and effect upon the final passing thereof.

**READ A FIRST AND SECOND TIME, CONSIDERED READ A THIRD TIME AND
FINALLY PASSED THIS 29TH DAY OF APRIL, 2024**

Mayor
Grant Jones

CAO/Clerk
Lisa Higgs

ORGANIC WASTE PROCESSING AGREEMENT

THIS AGREEMENT is made this 19th day of April, 2024, BETWEEN: **Corporation of the Township of Southwold**, a township corporation with its head office located at 35663 Fingal Line, Fingal Ontario, N0L 1K0 (hereinafter referred to as "Customer"), AND: **Convertus Canada Ltd.**, a corporation incorporated under the laws of Ontario with its head office located at 8-307 Commissioners Road West, London ON, N6J 1Y4 (hereinafter referred to as "Service Provider").

WHEREAS the Customer is responsible for the collection of organic waste within its jurisdiction; and

WHEREAS the Service Provider is engaged in the business of receiving and processing organic waste;

NOW, THEREFORE, in consideration of the mutual covenants and agreements hereinafter set forth, the parties hereto agree as follows:

1. SCOPE OF SERVICES

The Service Provider shall receive and process all organic waste collected by the Customer. The term "organic waste" shall be defined as food waste collected in the municipal green bin program.

2. TERM

The term of this Agreement shall commence on May 15, 2024, and shall continue for a period of twenty (20) years unless earlier terminated as provided herein.

3. PRICING

The Customer agrees to pay the Service Provider a fee of \$80 per tonne of organic waste processed in the first year of the Agreement. Thereafter, the price shall increase annually in accordance with the Consumer Price Index (CPI) until the fourth year of the contract. Beginning in the fifth year of the contract, the price shall adjust to an agreed-upon market rate, with Convertus Canada Ltd. presenting evidence of current market rates leading up to contract year five.

4. EXCLUSIVITY

During the term of this Agreement, the Customer agrees to deliver all organic waste collected by it exclusively to the Service Provider.

5. CONTAMINATION CLAUSE

For the purposes of this Agreement, "Contamination" shall be defined as the presence of in-organic material within the load of Organic Waste. If contamination is deemed higher than 10% by visual inspection, the Service Provider shall take a photo of the load, share it with the Customer, then dispose of the load at a landfill, charging the Customer the tip fee plus the cost of disposal at the landfill to compensate for the additional time and effort for the contaminated load.

6. DEFINITION OF TIP FEE

"Tip Fee" shall refer to the Fee for the acceptance and processing of Organic Waste as defined within this Agreement.

7. PAYMENT TERMS

The Service Provider shall invoice the Customer monthly for Organic Waste processed in the month prior. Payment terms shall be net 30 days from the date of the invoice.

8. DELIVERY REGIME

The Customer agrees to biweekly delivery of Organic Waste, to be carried out on the same day of the week each time. Should a scheduled delivery day fall on a recognized holiday, the delivery may be pushed to the next business day.

9. OWNERSHIP OF GREENHOUSE GAS CREDITS

Any and all carbon credits, greenhouse gas offsets, or similar benefits derived from the processing of Organic Waste under this Agreement ("Carbon Credits") shall be the sole property of Convertus Canada Ltd.

10. DISPUTE RESOLUTION

In the event of any dispute arising out of or relating to the adjustment of fees in year 5 of this Agreement, the parties agree to first attempt to negotiate a resolution. If negotiation is unsuccessful, the dispute shall be submitted to arbitration in accordance with the Arbitration Act of Ontario. The decision of the arbitrator shall be final and binding upon the parties.

11. MUTUAL TERMINATION

Either party may terminate this Agreement for convenience upon giving the other party sixty (60) days written notice.

12. GOVERNING LAW

This Agreement shall be governed by and construed in accordance with the laws of Ontario.

13. ENTIRE AGREEMENT

This Agreement constitutes the entire agreement between the parties with respect to the subject matter hereof and supersedes all prior agreements, understandings, negotiations, and discussions, whether oral or written, of the parties.

Signature Page Follows

IN WITNESS WHEREOF, the parties hereto have executed this Agreement as of the first date written above.

CUSTOMER (Corporation of the Township of Southwold):

By: _____

Name: **Grant Jones**

Title: **Mayor**

Date: 2024/04/29

SERVICE PROVIDER (Convertus Canada Ltd.):

By: _____

Name: **Mike Leopold**

Title: **CEO**

Date:



**THE CORPORATION OF THE TOWNSHIP OF
SOUTHWOLD BY- LAW NO. 2024-26**

Being a by-law to confirm the resolutions and motions of the Council of the Township of Southwold, which were adopted on April 29, 2024.

WHEREAS Section 5(3) of the Municipal Act, 2001, Chapter 25, provides that a municipal power, including a municipality's capacity, rights, powers and privileges under section 8, shall be exercised by by-law unless the municipality is specifically authorized to do otherwise;

AND WHEREAS it has been expedient that from time to time, the Council of the Corporation of the Township of Southwold should enact by resolution or motion of Council;

AND WHEREAS it is deemed advisable that all such actions that have been adopted by a resolution or motion of Council only should be authorized by By-law;

NOW THEREFORE THE COUNCIL OF THE CORPORATION OF THE TOWNSHIP OF SOUTHWOLD ENACTS AS FOLLOWS:

1. That the actions of the Council of the Township of Southwold at the Regular Meeting of Council held on April 29, 2024; in respect to each report, motion, resolution or other action passed and taken by the Council at its meetings, is hereby adopted, ratified and confirmed, as if each resolution or other action was adopted, ratified and confirmed by its separate by-law.
2. That the Mayor and the proper officers of the Corporation are hereby authorized and directed to do all things necessary to give effect to the said action, or obtain approvals, where required, and, except where otherwise provided, the Mayor and the Clerk are hereby directed to execute all documents necessary in that behalf and to affix the Corporate Seal of the Township of Southwold to all such documents.

READ A FIRST AND SECOND TIME, CONSIDERED READ A THIRD TIME, AND FINALLY PASSED THIS 29th DAY OF APRIL, 2024.

Mayor
Grant Jones

CAO/Clerk
Lisa Higgs